

PROGRAMMABLE CONTROLLER

FP7 CPU Unit

User's Manual

Hardware

Safety Precautions

Observe the following notices to ensure personal safety or to prevent accidents.
To ensure that you use this product correctly, read this User's Manual thoroughly before use.
Make sure that you fully understand the product and information on safety.
This manual uses two safety flags to indicate different levels of danger.

WARNING

If critical situations that could lead to user's death or serious injury is assumed by mishandling of the product.

- Always take precautions to ensure the overall safety of your system, so that the whole system remains safe in the event of failure of this product or other external factor.
- Do not use this product in areas with inflammable gas. It could lead to an explosion.
- Exposing this product to excessive heat or open flames could cause damage to the lithium battery or other electronic parts.
- Battery may explode if mistreated. Do not recharge, disassemble or dispose of fire.

CAUTION

If critical situations that could lead to user's injury or only property damage is assumed by mishandling of the product.

- To prevent excessive exothermic heat or smoke generation, use this product at the values less than the maximum of the characteristics and performance that are assured in these specifications.
- Do not dismantle or remodel the product. It could cause excessive exothermic heat or smoke generation.
- Do not touch the terminal while turning on electricity. It could lead to an electric shock.
- Use the external devices to function the emergency stop and interlock circuit.
- Connect the wires or connectors securely.
The loose connection could cause excessive exothermic heat or smoke generation.
- Ground the protective earth (PE) terminal (Class D grounding). Failure to do so could lead to an electric shock.
- Do not allow foreign matters such as liquid, flammable materials, metals to go into the inside of the product. It could cause excessive exothermic heat or smoke generation.
- Do not undertake construction (such as connection and disconnection) while the power supply is on. It could lead to an electric shock.

Copyright / Trademarks

- This manual and its contents are copyrighted.
- You may not copy this manual, in whole or part, without written consent of Panasonic Industrial Devices SUNX Co., Ltd.
- Windows is a registered trademark of Microsoft Corporation in the United States and other countries.
- Ethernet is a registered trademark of Fuji Xerox Co., Ltd. and Xerox Corp.
- All other company names and product names are trademarks or registered trademarks of their respective owners.

Introduction

Thank you for buying a Panasonic product. Before you use the product, please carefully read the installation instructions and the users manual, and understand their contents in detail to use the product properly.

Types of Manual

- There are different types of users manual for the FP7 series, as listed below. Please refer to a relevant manual for the unit and purpose of your use.
- The manuals can be downloaded on our website:
http://industrial.panasonic.com/ac/e/dl_center/manual/ .

Unit name or purpose of use	Manual name	Manual code	
FP7 Power Supply Unit			
FP7 CPU Unit	FP7 CPU Unit Users Manual (Hardware)	WUME-FP7CPUH	
	FP7 CPU Unit Command Reference Manual	WUME-FP7CPUPGR	
	FP7 CPU Unit Users Manual (Logging Trace Function)	WUME-FP7CPULOG	
	FP7 CPU Unit Users Manual (Security Function)	WUME-FP7CPUSEC	
	Instructions for Built-in LAN Port	FP7 CPU Unit Users Manual (LAN Port Communication)	WUME-FP7LAN
	Instructions for Built-in COM Port	FP7 series Users Manual (SCU communication)	WUME-FP7COM
FP7 Extension Cassette (Communication) (RS-232C/RS485 type)			
FP7 Extension Cassette (Communication) (Ethernet type)	FP7 series Users Manual (Communication cassette Ethernet type)	WUME-FP7CCET	
FP7 Extension (Function) Cassette Analog Cassette	FP7 Analog Cassette Users Manual	WUME-FP7FCA (Upcoming)	
FP7 Digital Input/Output Unit	FP7 Digital Input/Output Unit Users Manual	WUME-FP7DIO	
FP7 Analog Input Unit	FP7 Analog Input Unit Users Manual	WUME-FP7AIH	
FP7 Analog Output Unit	FP7 Analog Output Unit Users Manual	WUME-FP7AOH	
Thermocouple multi-analog input unit	Thermocouple multi-analog input unit RTD input unit Users Manual	WUME-FP7TCRTD	
RTD input unit			
FP7 High-speed counter Unit	FP7 High-speed counter Unit Users Manual	WUME-FP7HSC	
FP7 Pulse Output Unit	FP7 Pulse Output Unit Users Manual	WUME-FP7PG	
FP7 Positioning Unit	FP7 Positioning Unit Users Manual	WUME-FP7POSP	
FP7 Serial Communication Unit	FP7 series Users Manual (SCU communication)	WUME-FP7COM	
PHLS System	PHLS System Users Manual	WUME-PHLS	
Programming Software FPWIN GR7	FPWIN GR7 Introduction Guidance	WUME-FPWINGR7	

Selection of CPU Units

Note the following points when selecting a CPU unit.

■ Specification changes of CPU unit

- The firmware version of CPU units has been changed in accordance with the extension of the specifications. Specify units with new model numbers.

		Conventional model number (Ver.1)		New model number (Ver.2 / Ver.3)	
Program capacity	Ethernet function	With Encryption function		No Encryption function	With Encryption function
196K steps	Available	AFP7CPS4E	→	AFP7CPS41E	AFP7CPS41ES
120K steps	Available	AFP7CPS3E	→	AFP7CPS31E	AFP7CPS31ES
	Not available	AFP7CPS3	→	AFP7CPS31	AFP7CPS31S

- The CPU units Ver.2 and Ver.3 are upward compatible with the conventional Ver.1.
- For using CPU units Ver.2, Ver.2.0 or later version of FPWIN GR7 is required.
- For using CPU units Ver.3, Ver.2.4 or later version of FPWIN GR7 is required.
- For using the projects (programs, comments and configuration data) created for the conventional CPUs Ver.1, the projects must be converted to the projects for CPU units Ver.2 or Ver.3 using the "Convert PLC Type" function of the tool software.
- For information on the CPU versions and FPWIN GR7 version that can be used with each unit and extension cassettes, refer to "1.2 Restrictions on Combinations of Units".
- The layout of the operation monitor LEDs on Ver.1 of the CPU unit is different from that on Ver.2 or later.

■ Regulations on Encryption function in China

- Some CPU units have the encryption function which encrypts a part or all parts of programs in projects.
- In China, the types equipped with the encryption function cannot be used as they are subject to "Regulation of Commercial Encryption Codes". For using machines or systems incorporating FP7 series in China, or exporting and importing them, select the types without the encryption function.

Table of Contents

1. Overview 1-1

1.1	System Configuration	1-2
1.1.1	List of Units.....	1-2
1.2	Restrictions on Combinations of Units	1-4
1.2.1	Common Restrictions on Each Unit	1-4
1.2.2	Restrictions on the Number of Installed Units	1-4
1.2.3	Restrictions on the Combination of Extension Cassettes	1-5
1.2.4	Restrictions on Communication Functions to be Used	1-5
1.2.5	Unit to be Used and Applicable Versions of CPU Unit and FPWIN GR71-6	
1.3	Restrictions on Using Expansion Unit	1-7
1.3.1	Configuration When Using Expansion Unit	1-7
1.3.2	Restrictions on Combinations of Units	1-8
1.3.3	Installation Position of Units and Access Time	1-9
1.3.4	Restrictions on Configuration Capacity	1-9
1.4	Selection of Power Supply and Restrictions on Combination	1-11
1.4.1	Power Supply for Internal Circuit.....	1-11
1.4.2	List of Power Supply Unit's Current Consumption for Internal Circuit...1-13	
1.4.3	Power Supply for External Circuit	1-15
1.5	Programming Tools	1-16

2. Names and Functions of Parts 2-1

2.1	CPU Unit	2-2
2.2	Power Supply Unit.....	2-5
2.3	Expansion Master Unit / Expansion Slave Unit	2-6

3.	I/O Number Allocation.....	3-1
3.1	Basics of I/O Allocation.....	3-2
3.1.1	How to Count the I/O Numbers.....	3-2
3.1.2	Concept of I/O Number Allocation.....	3-2
3.1.3	List of Occupied I/O Points for Each Unit.....	3-4
3.2	Optional Allocation Using FPWIN GR7.....	3-6
3.2.1	Registration of a Unit to be Used and the Starting Word Number.....	3-6
3.2.2	Optional Settings in the “Unit Selection” Dialog Box.....	3-8
3.2.3	Settings When Using Expansion Unit.....	3-9
3.3	Mount Allocation Using FPWIN GR7.....	3-10
3.3.1	Mount Registration of a Unit to be Used and the Starting Word Number.....	3-10
3.3.2	Changing the Starting Word Number.....	3-11
3.4	Automatic Allocation.....	3-12
3.4.1	Allocation without Using FPWIN GR7.....	3-12
3.5	I/O Map Registration.....	3-13
3.5.1	I/O Map Registration.....	3-13
3.5.2	I/O Map Clearance.....	3-13
4.	Installation and Wiring.....	4-1
4.1	Installation.....	4-2
4.1.1	Installation Environment and Space.....	4-2
4.1.2	Attaching Units.....	4-4
4.1.3	DIN Rail Attachment.....	4-6
4.2	Wiring the Power Supply.....	4-8
4.2.1	Common Precautions.....	4-8
4.2.2	Wiring for Power Supply Units.....	4-9
4.2.3	Wiring for the Power Supply Part of the CPU Unit.....	4-10
4.2.4	Wiring of Power Supply Part of Expansion Slave Unit.....	4-10
4.2.5	Grounding.....	4-11

4.3	Wiring of Expansion Cable	4-12
4.3.1	Expansion Cable Type	4-12
4.3.2	Connection of Function Earth Wire	4-12
4.3.3	Connecting Position and Direction of Expansion Cables	4-13
4.4	Safety Measures	4-14
4.4.1	Safety Circuit	4-14
4.4.2	Momentary Power Drop	4-14
4.4.3	Alarm Output	4-15

5. Operation 5-1

5.1	Before Powering On	5-2
5.1.1	Check Points	5-2
5.1.2	Procedures before Starting Operation	5-3
5.2	RAM/ROM Operation	5-4
5.2.1	Transmission of the Project	5-4
5.2.2	Operations following Powering On	5-5
5.2.3	Data Hold During Power Failure	5-6
5.2.4	Online Editing	5-6
5.3	Backing Up the Project	5-7
5.3.1	Transmission from the Execution Memory RAM to the Backup Memory ROM2	5-7
5.3.2	Transmission from the Backup Memory ROM2 to the Execution Memory RAM/ROM1	5-8
5.3.3	Operations following Powering On/Off	5-8
5.4	SD Memory Card Operation	5-9
5.4.1	Preparing SD Memory Cards	5-9
5.4.2	How to Insert an SD Memory Card	5-10
5.4.3	Saving an Execution File for SD Memory Card Operation	5-11
5.4.4	Provisional Operation by an SD Memory Card	5-12
5.4.5	Transmission from an SD Memory Card to the Execution Memory	5-14
5.4.6	Precautions Concerning SD Memory Card Operation	5-15
5.5	Operation When Using Expansion Master Unit/Slave Unit	5-16

5.5.1	Operation When Power Supply Turns ON/OFF	5-16
5.5.2	Insertion and Removal of Expansion Cable	5-16
6.	Troubleshooting	6-1
6.1	Self-Diagnosis Function	6-2
6.1.1	CPU Unit's Operation Monitor LED	6-2
6.1.2	Operation at the Time of Error	6-2
6.2	What to Do If an Error Occurs	6-3
6.2.1	ERROR LED Flashes on the CPU Unit	6-3
6.2.2	PROG Mode Does Not Change to RUN	6-4
6.2.3	ALARM LED Turns ON on the CPU Unit	6-4
6.2.4	POWER LED Does Not Turn ON on the Power Supply Unit	6-5
6.2.5	A Protect Error Message Appears	6-5
6.2.6	If Expected Output Is Not Available	6-6
6.2.7	ERR LED Turns ON on the Expansion Unit	6-7
7.	Maintenance and Inspection	7-1
7.1	Handling of Backup Battery	7-2
7.1.1	Functions of Backup Battery	7-2
7.1.2	Replacement of Backup Battery	7-3
7.1.3	Lifetime and Replacement Interval of Backup Battery	7-4
7.2	Inspection	7-5
8.	Specifications	8-1
8.1	CPU Unit Specifications	8-2
8.1.1	General Specifications	8-2
8.1.2	Performance Specifications	8-4
8.1.3	CPU Unit Communication Specifications	8-6
8.1.4	Operation Memory Area	8-8

8.1.5	List of System Relays.....	8-10
8.1.6	List of System Data Registers.....	8-17
8.1.7	Error Codes Table.....	8-20
8.2	Power Supply Unit Specifications.....	8-25
8.2.1	General Specifications.....	8-25
8.2.2	Performance Specifications.....	8-26
8.2.3	Alarm Output Specifications.....	8-26
8.3	Dimensions.....	8-27
8.3.1	Power Supply Unit.....	8-27
8.3.2	CPU Unit.....	8-28
8.3.3	Terminal Block Type Unit (1).....	8-28
8.3.4	Terminal Block Type Unit (2).....	8-29
8.3.5	Connector Type Unit.....	8-30
8.3.6	Serial Communication Unit.....	8-31
8.3.7	PHLS Master Unit.....	8-31
8.3.8	End Unit.....	8-32
8.3.9	Figures of Unit Combination.....	8-33

1

Overview

1.1 System Configuration

1.1.1 List of Units

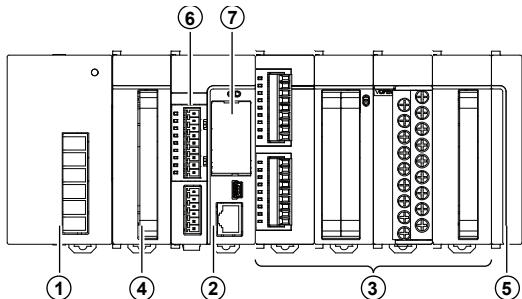

① Power Supply Unit

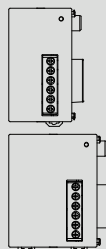

Model number	Remarks
AFP7PSA1	100 to 240V AC, 24W

Model number	Remarks
AFP7PSA2	100 to 240V AC, 43W

② CPU Unit

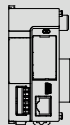

Model number	Remarks
AFP7CPS4E	196k steps With Ethernet function
AFP7CPS3E	120k steps With Ethernet function
AFP7CPS3	120k steps With Ethernet function
AFP7CPS41E	196k steps With Ethernet function
AFP7CPS31E	120k steps With Ethernet function
AFP7CPS31	120k steps Without Ethernet function
AFP7CPS41ES	196k steps With Ethernet function With Encryption function
AFP7CPS31ES	120k steps With Ethernet function With Encryption function
AFP7CPS31S	120k steps Without Ethernet function With Encryption function

③ Digital I/O Units



Model number	Remarks
AFP7X16DW	Input 16-point, 12 to 24VDC
AFP7Y16R	Output 16-point, Relay
AFP7Y16T	Output 16-point, Sink type
AFP7Y16P	Output 16-point, Source type

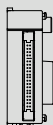

Model number	Remarks
AFP7X32D2	Input 32-point, 24V DC
AFP7Y32T	Output 32-point, Sink type
AFP7Y32P	Output 32-point, Source type

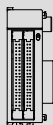

Model number	Remarks
AFP7X64D2	Input 64-point, 24V DC
AFP7Y64T	Output 64-point, Sink type
AFP7Y64P	Output 64-point, Source type
AFP7XY64D2T	Input 32-point, 24V DC Output 32-point, Sink type
AFP7XY64D2P	Input 32-point, 24V DC Output 32-point, Source type

③ Analog I/O Units



Model number	Remarks
AFP7AD4H	Input 4ch
AFP7AD8	Input 8ch
AFP7DA4H	Output 4ch



Model number	Remarks
AFP7TC8	Thermocouple, Input 8ch
AFP7RTD8	RTD, Input 8ch

③ High-speed Counter Unit



Model number	Remarks
AFP7HSC2T	2ch



Model number	Remarks
AFP7HSC4T	4ch

③ Pulse Output Unit

Model number	Remarks
AFP7PG02T	2-axis, Pulse train, 500kpps Open collector output
AFP7PG02L	2-axis, Pulse train, 4Mpps Line driver output

Model number	Remarks
AFP7PG04T	4-axis, Pulse train, 500kpps Open collector output
AFP7PG04L	4-axis, Pulse train, 4Mpps Line driver output

③ Positioning Unit

Model number	Remarks
AFP7PP02T	2-axis, Pulse train, 500kpps Open collector output
AFP7PP02L	2-axis, Pulse train, 4Mpps Line driver output

Model number	Remarks
AFP7PP04T	4-axis, Pulse train, 500kpps Open collector output
AFP7PP04L	4-axis, Pulse train, 4Mpps Line driver output

③ Serial Communication Unit

Model number	Remarks
AFP7NSC	Selectable combination of two interfaces from AFP7CCS1 、 AFP7CCS2 AFP7CCM1 、 AFP7CCM2 AFP7CCS1M1

④ Expansion unit

Model number	Remarks
AFP7EXPM	Master unit

Model number	Remarks
AFP7EXPS	Slave unit

⑤ End Unit



Connect to the end of system
Attaches to CPU unit.

⑥ Add-on Cassette (Optional)

• Communication Cassette

Model number	Remarks
AFP7CCS1	RS-232C × 1ch
AFP7CCS2	RS-232C × 2ch
AFP7CCM1	RS-422/RS-485 × 1ch
AFP7CCM2	RS-422/RS-485 × 2ch
AFP7CCS1M1	RS-232C × 1ch RS-485 × 1ch

Model number	Remarks
AFP7CCET1	Ethernet × 1ch

⑥ Add-on Cassette (Optional)

• Function Cassette

Model number	Remarks
AFP7FCA21	Analog input x 2ch Analog output x 1ch
AFP7FCAD2	Analog input x 2ch
AFP7FCTC2	Thermocouple input x 2ch

⑦ CPU Unit Attachment Options

• Backup battery

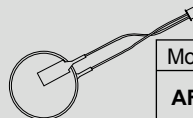

Model number	Remarks
AFPX-BATT	Only used for the <input type="checkbox"/> clock / calendar

• SD memory card



Commercially available products
For project backup and SD memory card operation

1.2 Restrictions on Combinations of Units

1.2.1 Common Restrictions on Each Unit

- You can use FP7 series combining the CPU unit with optional input/output units and intelligent units.
Up to 16 input/output units and intelligent units can be connected.
- Make sure to connect an end unit to the end of the system.
- You can either connect a power supply unit for system driving power, or directly supply power from an external 24 V DC power supply to the CPU unit. See “1.4 Selection of Power Supply and Restrictions on Combination” for restrictions on combination.
- For using an SD memory card, it is recommended to select a connector-type unit as a unit installed to the right of the CPU unit in order to prevent interference with the wirings of the unit.

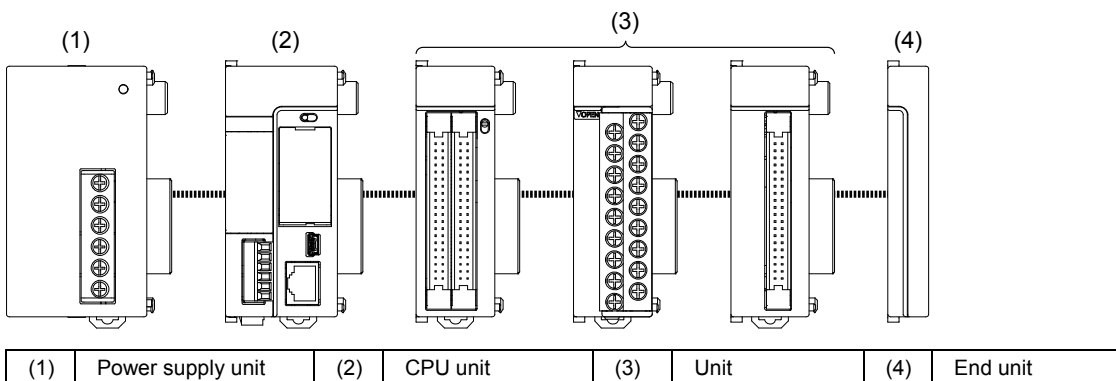

1.2.2 Restrictions on the Number of Installed Units

There are following restrictions depending on units to be used.

Unit type	Number of installed units	Remarks
Power Supply Unit, CPU Unit	Max. 1 unit	
Serial Communication Unit	Max. 8 units	

1.2.3 Restrictions on the Combination of Extension Cassettes

There are following restrictions depending on units and cassettes to be used.

Unit type	Number of attachable cassettes	Attachable add-on cassettes		
		Communication cassette AFP7CCS* AFP7CCM*	Communication cassette AFP7CCET	Application cassette AFP7FC*
CPU Unit	Max. 1 unit	Attachable	Attachable	Attachable
Serial Communication Unit	Max. 2 units per unit	Attachable	Not attachable	Not attachable

1.2.4 Restrictions on Communication Functions to be Used

There are the following restrictions on functions to be used when using the SCU or ET-LAN that is built in the CPU unit, or the serial communication unit (SCU).

Function to be used	Restrictions
PLC link function	Up to two communication ports can be used. For using two ports, allocate different link areas to them. SCU built-in the CPU unit (COM.1 port) Serial communication unit (COM.1 port)
MEWTOCOL-COM master MODBUS-RTU master	A maximum of 16 communication ports and the number of connections in combination can be used simultaneously. SCU built-in the CPU unit (COM.1 port to COM. 2 port) Serial communication unit (COM.1 port to COM.4 port) ET-LAN built-in the CPU unit (User connections 1 to 16)
MEWTOCOL-COM slave MEWTOCOL7-COM slave MODBUS-RTU slave	A maximum of 15 communication ports and the number of connections in combination can be used simultaneously. SCU built-in the CPU unit (COM.1 port to COM. 2 port) Serial communication unit (COM.1 port to COM.4 port) ET-LAN built-in the CPU unit (System connections 1 to 4 / User connections 1 to 16)
General-purpose communication	There is no restriction.

1.2.5 Unit to be Used and Applicable Versions of CPU Unit and FPWIN GR7

For using the unit, the following versions of CPU unit and FPWINGR7 are required.

Unit type	Applicable versions		Remarks
	CPU unit	FPWINGR7	
FP7 High-speed Counter Unit	Ver.1.2 or later	Ver.1.2 or later	(Note 1)
FP7 Serial Communication Unit	Ver.1.2 or later	Ver.1.3 or later	
FP7 Communication Cassette (Ethernet type)	Ver.1.3 or later	Ver.1.0 or later	(Note 2)
FP7 Analog I/O Cassette, Analog Input Cassette, Thermocouple Input Cassette	Ver.2.0 or later	Ver.2.0 or later	
FP7 Pulse Output Unit	Ver.2.0 or later	Ver.2.0 or later	
Thermocouple Multi-analog Input Unit RTD Input Unit	Ver.2.0 or later	Ver.2.3 or later	
FP7 Analog Input Unit (AFP7AD8)	Ver.3.1 or later	Ver.2.4 or later	
FP7 Expansion Master Unit FP7 Expansion Slave Unit	Ver.3.1 or later	Ver.2.4 or later	

(Note 1) For using the high-speed counter unit and the positioning unit in combination, and for using the interrupt function with the high-speed counter unit, the positioning unit Ver.1.1 or later is required.

(Note 2) Configurator WD should be Ver.1.7 or later.

1.3 Restrictions on Using Expansion Unit

1.3.1 Configuration When Using Expansion Unit

- In FP series, blocks in which units are combined with the expansion master unit and expansion slave units can be added.
- From 0 to 16 I/O units and intelligent units can be combined in one block.
- Up to 3 expansion blocks can be connected to one CPU unit.

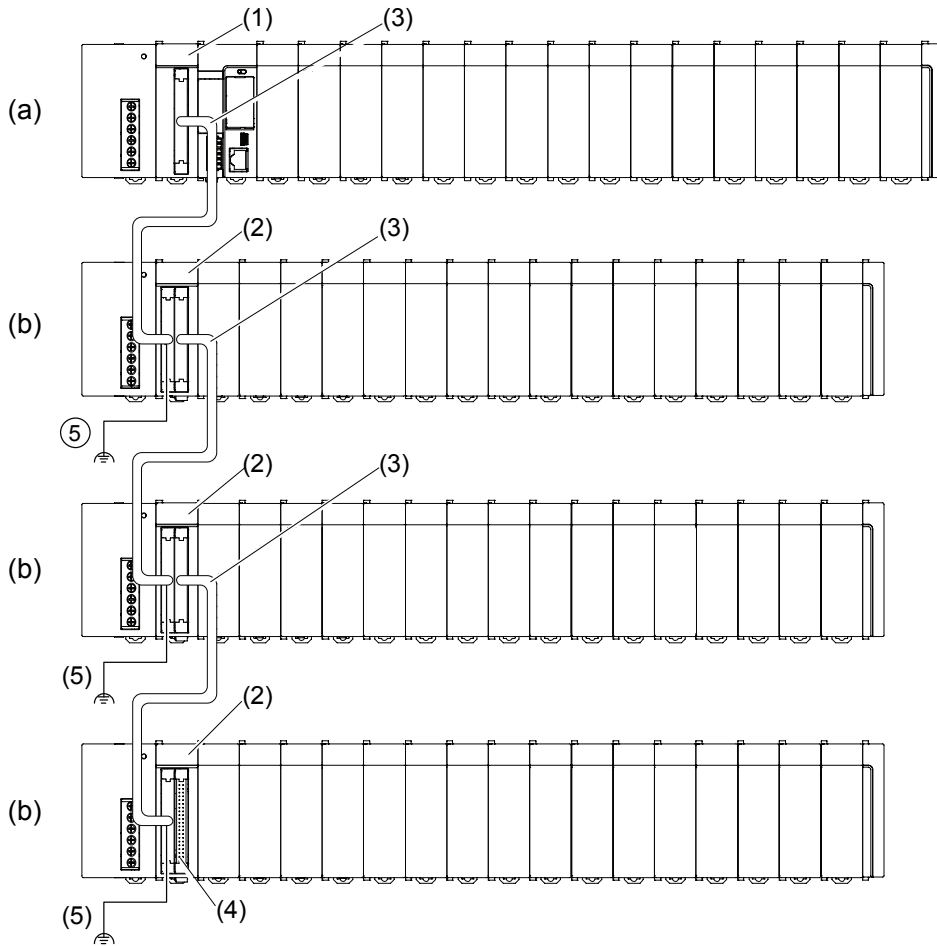

(a)	Base block	(1)	Expansion master unit	(3)	Expansion cable		
(b)	Expansion block	(2)	Expansion slave unit	(4)	Dummy connector	(5)	Earth wire of expansion cable

1.3.2 Restrictions on Combinations of Units

■ Combinations of base block

- Install the expansion master unit AFP7EXPM on the left-hand side of the CPU unit.
- Install the power supply unit on the left-hand side of the expansion master unit AFP7EXPM as necessary.

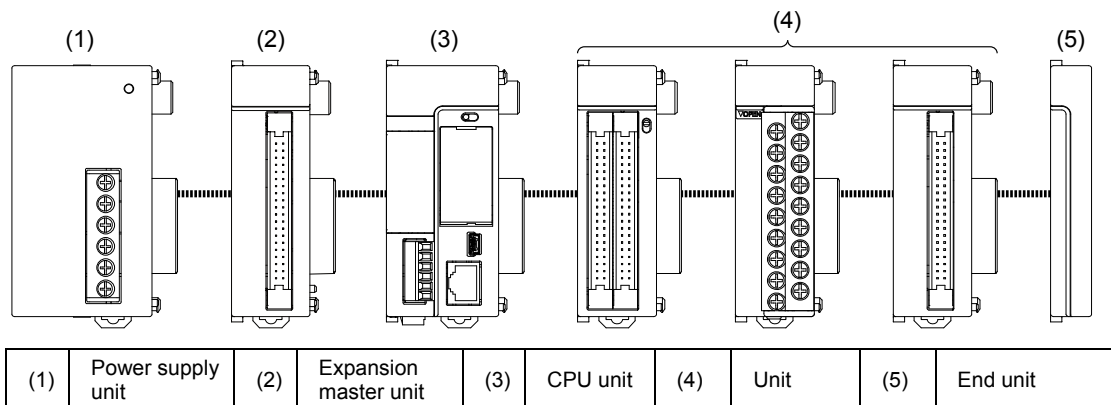

■ Combinations of expansion block

- Install the expansion slave unit AFP7EXPS on the left-hand side of the CPU unit.
- Install the power supply unit on the left-hand side of the expansion master unit AFP7EXPM if used.

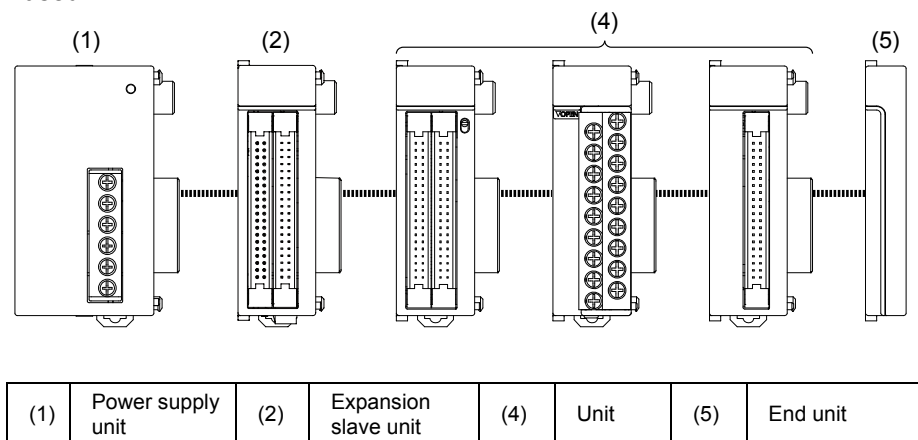

■ Base block and expansion block common restrictions

- Make sure to connect the end unit to the right side of the terminal unit.
- As a power supply for driving the system, you can either connect the power supply unit used at 100 V/230 V AC, or directly supply 24 V DC power to the CPU unit and expansion slave units. For the restrictions on combinations, refer to 1.4 Selection of Power Supply and Restrictions on Combination

1.3.3 Installation Position of Units and Access Time

■ Restrictions on installation position of units

- There is no restriction on the installation position of each unit in FP7 series. However, the access time to the units installed in the expansion block is longer than that to the units installed in the base block as shown in the table below, and it affects the scan time.
- When large-volume data access is assumed with a communication system unit, a unit in which interrupt occurs or user programs, it is recommended to install the target units in the base block. It enables to decrease the scan time relatively.

■ Difference in access time between installation positions of units

Installation position	Access time		Remarks
	Time per word	Ratio to base block	
Base block	0.47 μ s/word	Even	
Expansion block (Short distance mode)	2.5 μ s/word	5.3 times	The total length of expansion cables is 9 m or less. The LED "SP0" on the expansion master unit turns on.
Expansion block (Long distance mode)	4.1 μ s/word	8.7 times	The total length of expansion cables is 10 m to 30 m. The LED "SP1" on the expansion master unit turns on.

(Note 1) The values in the above table indicate each time which the CPU unit accesses the units installed in each block via bus in the I/O refresh processing or operation processing. The scan time that an operation processing time and base time are added can be confirmed in the status display dialog box of the tool software.

1.3.4 Restrictions on Configuration Capacity

■ Unit configuration capacity

- If units in which a lot of configuration data are set such as a positioning unit are used in the expansion block a lot, the configuration capacity may exceed the capacity that the CPU unit can handle.
- Check the configuration capacity in the I/O map dialog box of the tool software in advance.
- The configuration capacity varies according to the functions and settings used in each unit. Also, the maximum registration capacity to be assigned depends on the number of installed expansion units.



◆ KEY POINTS

- The configuration capacity can be checked on the "I/O map" dialog box in FPWIN GR7 Ver.2.4 or later.

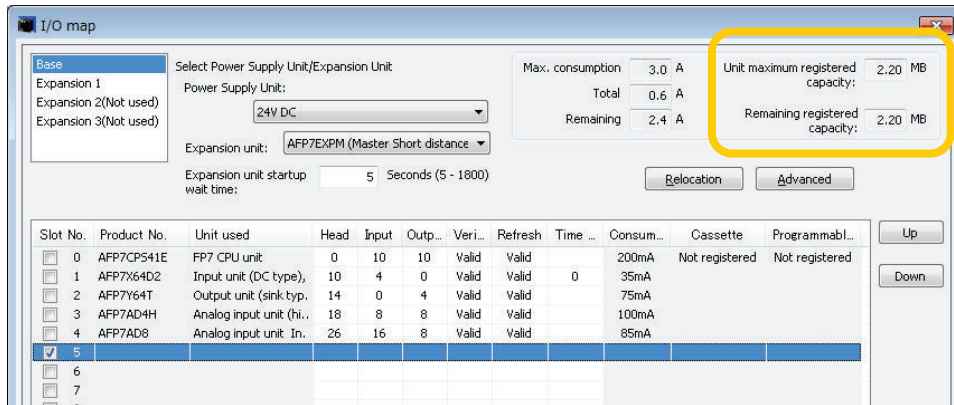

1.4 Selection of Power Supply and Restrictions on Combination

1.4.1 Power Supply for Internal Circuit

■ Restrictions on combination of power supply for internal circuit and units

- Power for internal circuit is supplied from a power supply terminal of the power supply unit or the CPU unit, or a power supply terminal of the expansion slave unit.
- Select units within the respective restrictions indicated below.

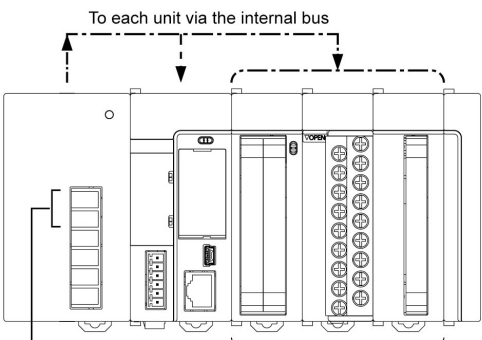
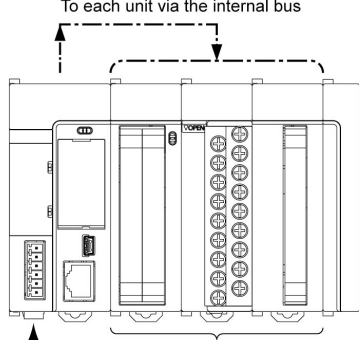
When a power supply unit is used	When no power supply unit is used
 <p data-bbox="161 989 655 1027">Supplied from an external power supply 100-240V AC</p> <p data-bbox="450 981 628 1027">I/O unit High-performance unit</p>	 <p data-bbox="782 1000 1125 1039">Supplied from an external power supply 100-240V AC</p> <p data-bbox="953 973 1131 1012">I/O unit High-performance unit</p>
<p data-bbox="167 1078 655 1168">Select units so that the sum of internal current consumptions of connected input/output units and intelligent units does not exceed the capacity of the power supply unit.</p>	<p data-bbox="716 1078 1186 1168">Select units so that the sum of internal current consumptions of connected input/output units and intelligent units does not exceed max. 2 A or 3 A (Note 1).</p>

(Note 1) The allowable current without the power supply unit varies according to the model numbers of CPU unit. Refer to the next page.

(Note 2) The allowable current of the expansion slave unit without the power supply unit is max. 3 A.

■ Selection of a 24V DC power supply

- Select a power supply larger than the capacity of the units. In the minimum configuration, select a power supply of 24 W or larger.
- In order to protect the unit against abnormal voltage from the power supply line, the power supply should be an insulated type, and should be enclosed within a protective circuit.
- If using a power supply device without an internal protective circuit, always make sure power is supplied to the unit through a protective element such as a fuse.



◆ NOTE

When a power supply unit is used, do not connect a DC power supply to the CPU unit. It is the same for an expansion slave unit.

■ Allowable current (24 V) of CPU unit when power is directly supplied

Product name		Model number	Max. allowable current
CPU Unit	Ver.1	AFP7CPS4E/AFP7CPS3E/AFP7CPS3	2A
	Ver.2.0 or later	AFP7CPS41E AFP7CPS31E AFP7CPS31 AFP7CPS41ES/ AFP7CPS31ES/AFP7CPS31S	3A
Expansion Slave Unit		AFP7EXPS	3A

■ Output current of power supply units (24V)

Product name	Model number	Rated output current
Power Supply Unit	100 to 240V AC, 24W	AFP7PSA1
	100 to 240V AC, 43W	AFP7PSA2



◆ KEY POINTS

- The current consumption can be checked on the I/O map" dialog box in FPCWIN GR7 Ver.2.3 or later.

The screenshot shows the 'I/O map' dialog box. It includes a 'Base' section with expansion slots (1-3) marked as 'Not used'. The 'Power Supply Unit' is set to '24V DC' and the 'Expansion unit' is 'Not used'. The 'Expansion unit startup wait time' is set to 5 seconds. The 'Max. consumption' summary shows: Max. consumption 3.0 A, Total 1.0 A, Remaining 2.0 A; Unit maximum registered capacity 1.20 MB, Remaining registered capacity 1.20 MB. A table lists units in slots 0-9, including CPU unit, input/output units, analog input, thermocouple, counter, pulse output, positioning driver, SCU, and PHL5 master unit. The 'Consum...' column shows current values like 290mA, 35mA, 75mA, 100mA, 80mA, 65mA, 65mA, 110mA, and 85mA. Buttons for 'Relocation' and 'Advanced' are visible.

1.4.2 List of Power Supply Unit's Current Consumption for Internal Circuit

■ Unit's current consumption table (24V)

Product name		Model number	Current consumption (mA)	
CPU Unit	196k steps, Built-in Ethernet function	AFP7CPS4E AFP7CPS41E AFP7CPS41ES	200 mA or less	
	120k steps, Built-in Ethernet function	AFP7CPS3E AFP7CPS31E AFP7CPS31ES	200 mA or less	
	120k steps, No Ethernet function	AFP7CPS3 AFP7CPS31 AFP7CPS31S	200 mA or less	
Add-on Cassette (Communication Cassette) (Note 1) (Note 2) When attaching to CPU unit	RS-232C x 1ch	AFP7CCS1	35 mA or less	
	RS-232C x 2ch	AFP7CCS2	60 mA or less	
	RS-422 / 485 x 1ch	AFP7CCM1	60 mA or less	
	RS-422 / 485 x 2h	AFP7CCM2	90 mA or less	
	RS-232C x 1ch RS-485 x 1ch	AFP7CCS1M1	70 mA or less	
	Ethernet	AFP7CCET1	35 mA or less	
Add-on Cassette (Function Cassette)	Analog I/O cassette	AFP7FCA21	75 mA or less	
	Analog input cassette	AFP7FCAD2	40 mA or less	
	Thermocouple input cassette	AFP7FCTC2	45 mA or less	
Input Unit	DC Input	16-point terminal block, 5 to 24 V DC	AFP7X16DW	25 mA or less
		32-point MIL connector, 24V DC	AFP7X32D2	30 mA or less
		64-point MIL connector, 24V DC	AFP7X64D2	35 mA or less
Output Unit	Relay output	16-point terminal block	AFP7Y16R	180 mA or less
	Transistor output	16-point terminal block, sink type	AFP7Y16T	35 mA or less
		32-point MIL connector, sink type	AFP7Y32T	50 mA or less
		64-point MIL connector, sink type	AFP7Y64T	75 mA or less
		16-point terminal block, source type	AFP7Y16P	35 mA or less
		32-point MIL connector, source type	AFP7Y32P	50 mA or less
64-point MIL connector, source type	AFP7Y64P	75 mA or less		
I/O mixed unit	Input 32-point / output 32-point MIL connector, sink type		AFP7XY64D2T	55 mA or less
	Input 32-point / output 32-point MIL connector, source type		AFP7XY64D2P	55 mA or less

(Continued on the next page)

Overview

Product name		Model number	Current consumption (mA)
Analog Input Unit	4ch	AFP7AD4H	100 mA or less
	8ch	AFP7AD8	85 mA or less
Analog Output Unit	4ch	AFP7DA4H	250 mA or less
Thermocouple Multi-analog Input Unit		AFP7TC8	80 mA or less
RTD Input Unit		AFP7RTD8	65 mA or less
High-speed Counter Unit	2-ch type	AFP7HSC2T	65 mA or less
	4-ch type	AFP7HSC4T	65 mA or less
Pulse Output Unit	2-axis, open collector output	AFP7PG02T	65 mA or less
	4-axis, open collector output	AFP7PG04T	65 mA or less
	2-axis, line driver output	AFP7PG02L	65 mA or less
	4-axis, line driver output	AFP7PG04L	65 mA or less
Positioning Unit	2-axis, open collector output	AFP7PP02T	120 mA or less
	4-axis, open collector output	AFP7PP04T	120 mA or less
	2-axis, line driver output	AFP7PP02L	120 mA or less
	4-axis, line driver output	AFP7PP04L	120 mA or less
Serial Communication Unit		AFP7NSC	50 mA or less
Extension Cassette (Communication Cassette) (Note 1) (Note 2) When attaching to Serial Communication Unit	RS-232C x 1ch	AFP7CCS1	20 mA or less
	RS-232C x 2ch	AFP7CCS2	40 mA or less
	RS-422 / 485 x 1ch	AFP7CCM1	30 mA or less
	RS-422 / 485 x 2h	AFP7CCM2	60 mA or less
	RS-232C x 1ch RS-485 x 1ch	AFP7CCS1M1	50 mA or less
PHLS master unit		AFP7RMTM	85 mA or less
Programmable display GT series (5V DC type) (Note 3)		-	100 mA or less
Expansion Master Unit (Note4)		AFP7EXPM	120 mA or less
Expansion Slave Unit (Note4)		AFP7EXPS	100 mA or less

(Note 1) Power consumption indicated under "Add-on Cassette" refers to the current consumption increment of the CPU unit following addition of the relevant cassette.

(Note 2) The consumption current of add-on cassette (communication cassette) varies according to the unit to which the cassette is attached (CPU unit or serial communication unit).

(Note 3) Power consumption indicated under "Display" refers to the current consumption increment of the CPU unit following connection of a GT series display (5V power supply type) to the GT power supply terminal of the CPU unit. For GT series displays (24V power supply type), please see their respective hardware specifications.

(Note 4) The current consumption of the expansion master unit and the expansion slave unit depends on the expansion cables used.

1.4.3 Power Supply for External Circuit

The 24 VDC power supply used as the input power supply of the input units and the output circuit driving power of the output units are supplied from the external terminal of each unit.

■ Unit's current consumption table (24V)

Product name		Model name	Current consumption (mA)	
Input Unit (Note 1)	DC Input	16-point terminal block, 5 to 24 V DC	AFP7X16DW	6 mA per point
		32-point MIL connector, 24V DC	AFP7X32D2	2.7 mA per point
		64-point MIL connector, 24V DC	AFP7X64D2	2.7 mA per point
Output Unit	Relay output	16-point terminal block	AFP7Y16R	-
	Transistor output	16-point terminal block, sink type	AFP7Y16T	70 mA or less
		32-point MIL connector, sink type	AFP7Y32T	110 mA or less
		64-point MIL connector, sink type	AFP7Y64T	140 mA or less
		16-point terminal block, source type	AFP7Y16P	70 mA or less
		32-point MIL connector, source type	AFP7Y32P	130 mA or less
		64-point MIL connector, source type	AFP7Y64P	180 mA or less
I/O mixed unit	Input 32-point / output 32-point MIL connector, sink type	AFP7XY64D2T	Input 2.7 mA per point Output 70 mA	
	Input 32-point / output 32-point MIL connector, source type	AFP7XY64D2P	Input 3.4 mA per point Output 90 mA	

(Note 1) Figures for input unit indicate current that flows into the internal circuit. Figures for other units indicate current values required for driving the internal circuit. This value does not include the load current of the output unit.

(Note 2) For current consumption of a 24 V power supply used for the I/O circuits of high-speed counter unit, pulse output unit and positioning unit, please see the User's Manual of each unit.

1.5 Programming Tools

■ Required tools

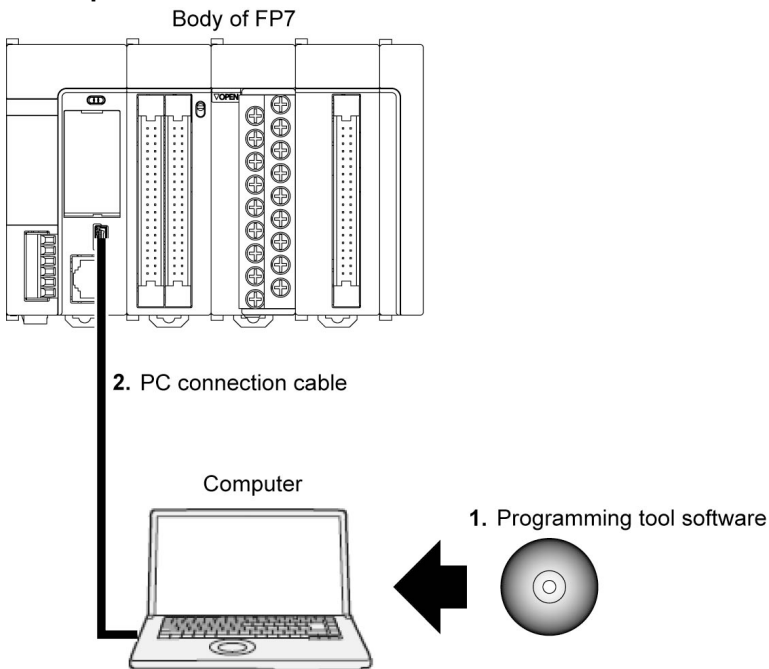

1. Tool software FPWIN GR7

- Dedicated to the FP7 series
- Used for program editing, debugging and documentation.

2. PC connection cable

- Use a commercial cable.

Cable type	Length
USB 2.0 cable (A:miniB)	Max. 5m

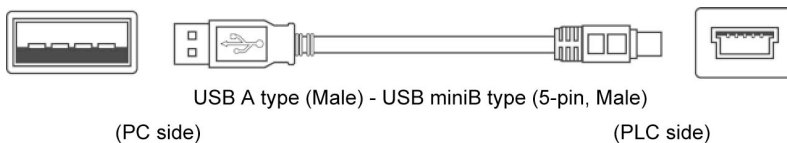

2

Names and Functions of Parts

2.1 CPU Unit

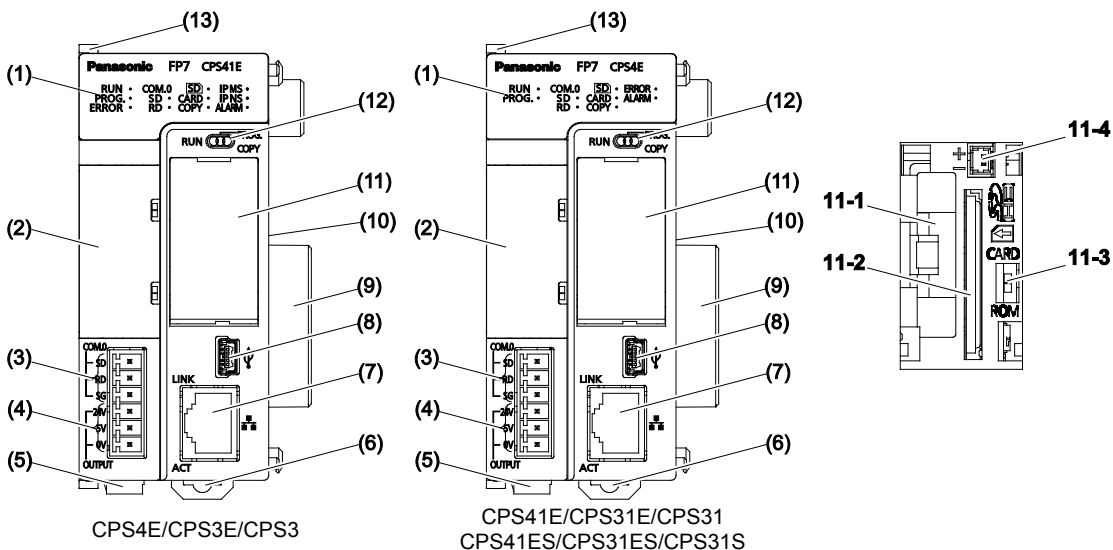

■ Names and functions of parts

(1) Operation monitor LEDs

Body display	LED color	Contents
-	Blue	Turns on when the CPU unit power is ON.
RUN	Green	Turns on in the RUN mode. Blinks during forced input/output.
PROG.	Green	Turns on in the PROG. mode.
COM.0	SD	Turns on while sending data from the COM.0 port.
	RD	Turns on while receiving data from the COM.0 port.
SD	Green	Turns on while accessing the SD memory card.
CARD	Green	Turns on while operation by the SD memory card is selected.
COPY	Green	Turns on during the COPY operation.
ERROR	Red	Turns on when an error has been detected through self-diagnosis.
ALARM	Red	Turns on if a hardware error occurs, or operation slows because of the program, and the watchdog timer is activated.

Note) The layout of the operation monitor LEDs in Ver.1 of the CPU unit is different from that in Ver.2 or later.

(2) Add-on cassette (Optional)

Attach an optional Add-on Cassette (Communication Cassette or Function Cassette).

(3) COM0 port terminal

3-wire RS-232C port

(4) GT power supply terminal

For our programmable display "GT series", either 5V DC or 24V DC can be used.

(5) Power supply connector

Connected with an external power supply (24V DC); When a power supply unit is used, do not connect this.

(6) DIN hook

Used for fixation on the DIN rail.

(7) LAN port (CPS4E, CPS41E, CPS41ES, CPS3E, CPS31E, CPS31ES)

Port for connection to Ethernet LAN

(8) USB port

Connected to a PC using the tool software

(9) Unit connectors

Connected to the internal circuit of I/O units and intelligent units

(10) Dip switches

Do not change the setting. The switches are all set to OFF at the factory.

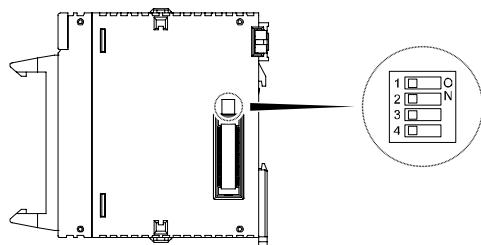
**(11) CF card cover**

Number	Name	Functions
11-1	Battery holder	Attach a battery.
11-2	SD memory card slot	Insert an SD memory card.
11-3	Card operation switch	Select between ROM operation or SD operation. By selecting SD operation, provisional operation from the SD memory card becomes possible.
11-4	Power supply connector	Connected to a power supply connector

(12) Mode switch

Switch position	Operation Mode
RUN (left)	Set to the RUN mode. The program is executed and operation begins.
PROG. (middle)	Set to the PROGRAM mode.
COPY (right, momentary)	When the switch is set to COPY, a project stored in the internal RAM / ROM1 is transmitted to ROM2 as a backup project.

(Note) Whether the switch is set to RUN or PROG., the mode can be switched through remote operation from the programming tool. When power is turned on again, it operates in the mode set on the switch.

(13) Fixing hook

Used for fixing a power supply unit to the CPU unit.

2.2 Power Supply Unit

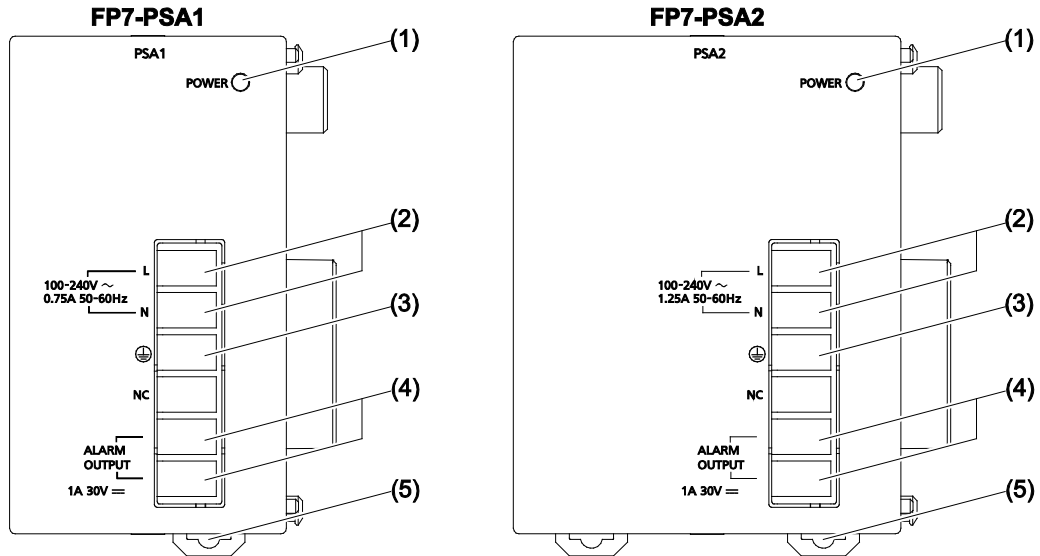

■ Names and functions of parts

(1) POWER LED (blue)

Turns on when power supply is turned on.

(2) Power supply terminals

Terminal block for power supply wiring. A solderless terminal for M3 can be used.

(3) Earth terminals

The unit should be grounded at a grounding resistance of 100 Ω or less to prevent noise and electric shock.

(4) Alarm contact output terminal

Closed when power supply is ON. If the watchdog timer is operated due to a hardware error or a program error, turning the relay contact into an open status.

(5) DIN rail attachment lever

Used for fixation on the DIN rail.

2.3 Expansion Master Unit / Expansion Slave Unit

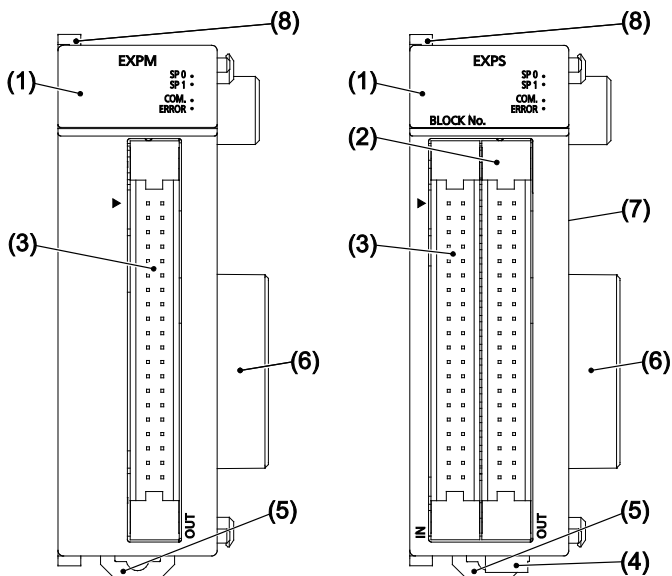

Names and functions of parts

(1) Operation monitor LEDs

Body display	LED color	Contents
SP0	Green	Turns on when the total length of standard expansion cables for combined units is 9 m or less.
SP1	Green	Turns on when the total length of standard expansion cables for combined units is 10 m or more.
COM.	Green	Blinks while communication between the expansion master unit and slave units is performed.
ERROR	Red	Turns on when an error occurs in the expansion system. Error in communication between the expansion master unit and slave units (such as communication cable unconnection or disconnection). Power supply error in expansion block Error in the I/O unit or intelligent unit installed in the expansion block. The end unit in the expansion block is not installed.
BLOCK No.	Green	(For the expansion master unit) The displayed L-shaped LED rotates during the initialization processing between the expansion master unit and the expansion slave unit. It turns off on the completion of the initialization. (For the expansion slave unit) The connected position numbers of expansion block, 1 to 3, are displayed with the LED. A 4x5 dot LED is used. When an error occurs in the initialization processing or the connection of expansion block, "0" is displayed.

(2) OUT connector

Used for connecting to the IN connector of the expansion slave unit in the next block with an exclusive expansion cable.

(3) IN connector

Used for connecting to the OUT connector of the expansion slave unit in the previous block with an exclusive expansion cable.

(4) Power supply connector (AFP7EXPS only)

Connected with an external power supply (24V DC); When a power supply unit is used, do not connect this.

(5) DIN hook

Used for fixing the unit on the DIN rail.

(6) Unit connector

Used for connecting the internal circuit of an I/O unit or intelligent unit. The end unit is attached with shipment.

(7) Dip switches

Do not change the setting. The switches are all set to OFF at the factory.

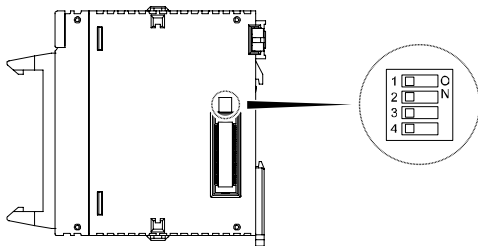

(8) Fixing hook

Used for fixing a power supply unit

3

I/O Number Allocation

3.1 Basics of I/O Allocation

3.1.1 How to Count the I/O Numbers

■ **Counting and expression of the I/O numbers**

Since I/O numbers are handled in units of 16 points, they are expressed as a combination of a device type code and the lowest-digit of a decimal or hexadecimal number.

E.g. In the case of an external input, X0 to X9 and XA to XF are used.

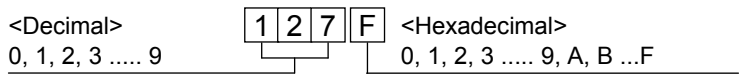

3.1.2 Concept of I/O Number Allocation

■ **Examples of I/O Number Allocation**

I/O numbers are determined by the status of unit attachment and the occupied I/O points allocated to respective units.

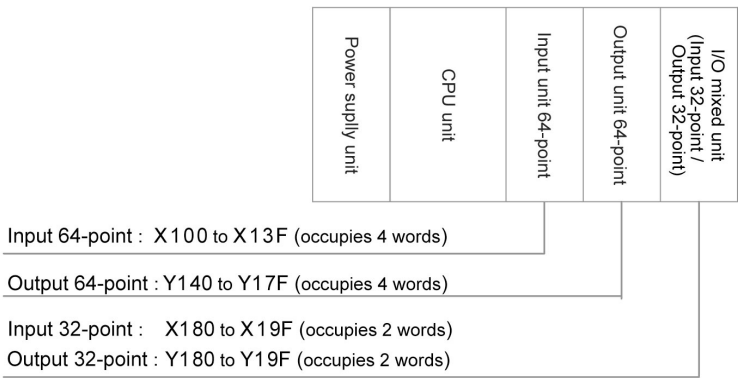

■ **Starting word numbers of input/output units and intelligent units**

- By default, the starting word number for the unit attached next to the CPU unit is set at "10", and the I/O numbers start with X100 or Y100.
- The starting word number for each unit can be freely changed in the "FP7 Configuration" menu of the tool software FPWIN GR7.

■ **How to count I/O numbers for units that have both inputs and outputs**

In the case of a unit that has both inputs and outputs (e.g. mixed input/output units, intelligent units), input numbers and output numbers start with the same value.

E.g. If input numbers for a mixed input/output unit are X100 to X11F, the unit's output numbers are set at Y100 to Y11F.

■ **I/O numbers allocated to the CPU unit**

A fixed area is allocated to the COM port and the ET-LAN port.



◆ **NOTE**

When the number of occupied input words is different from the number of occupied output words, the larger number is allocated to the unit.

3.1.3 List of Occupied I/O Points for Each Unit

■ CPU Unit

Unit Type		Model number	Occupied words (occupied I/O points)	
			Input	Output
CPU Unit	SCU built-in CPU Unit	Common	2 words (32 points) WX0-WX1	2 words (32 points) WY0-WY1
	Communication Cassette (Ethernet type)	AFP7CCET1	4 words (64 points) WX0-WX3	2 words (32 points) WY0-WY1
	Analog I/O Cassette	AFP7FCA21	2 words (32 points) WX2 to WX3	1 word (16 points) WY2
	Analog Input Cassette	AFP7FCAD2		—
	Thermocouple Cassette	AFP7FCTC2		—
	System reserved area	Common	WX4-WX5	WY4-WY5
	ET-LAN built-in CPU Unit	ET-LAN common occupied area		WX6
User connections 1 to 16			3 words (48 points) WX7-WX9	3 words (48 points) WY7-WY9
User connections 17 to 216			Max.26 words (416 points) WX11-WX36	Max.26 words (416 points) WY11-WY36

(Note 1) Input/output contacts of the CPU unit are allocated for the usage of communication functions of each cassette. Regardless of use of such functions, input occupies 10 words (160 points, WX0 to WX9) and output occupies 10 words (160 words, WY0 to WY 9).

(Note 2) Occupied area in the area of user connections 17 to 216 varies according to the number of used connections.

(Note 3) The starting numbers of I/O contacts of each unit including the CPU unit can be changed by the setting of the tool software.

■ I/O Unit

Unit Type		Model number	Occupied words (occupied I/O points)	
			Input	Output
Input/Output Units	Input unit 16 points	AFP7X16DW	1 word (16 points)	—
	Input unit 32 points	AFP7X32D2	2 words (32 points)	—
	Input unit 64 points	AFP7X64D2	4 words (64 points)	—
	Output unit 16 points	AFP7Y16R AFP7Y16T AFP7Y16P	—	1 word (16 points)
	Output unit 32 points	AFP7Y32T AFP7Y32P	—	2 words (32 points)
	Output unit 64 points	AFP7Y64T AFP7Y64P	—	4 words (64 points)
	Mixed input/output units Input 32 points / Output 32 points	AFP7XY64D2T AFP7XY64D2P	2 words (32 points)	2 words (32 points)

(Continued on the next page)

■ Intelligent Unit

Unit Type		Model number	Occupied words (occupied I/O points)	
			Input	Output
Intelligent Unit	Analog Input Unit	AFP7AD4H	8 words (128 points)	4 words (64 points)
		AFP7AD8	16 words (256 points)	8 words (128 points)
	Analog Output Unit	AFP7DA4H	4 words (64 points)	8 words (128 points)
	Thermocouple Multi-analog Input Unit	AFP7TC8	16 words (256 points)	8 words (128 points)
	RTD Input Unit	AFP7RTD8	16 words (256 points)	8 words (128 points)
	High-speed Counter Unit	AFP7HSC2T	8 words (128 points)	4 words (64 point)
		AFP7HSC4T		
	Pulse Output Unit	AFP7PG02T, AFP7PG02L	2 words (32 points)	2 words (32 points)
		AFP7PG04T, AFP7PG04L	4 words (64 points)	4 words (64 points)
	Positioning Unit	AFP7PP02T AFP7PP02L AFP7PP04T AFP7PP04L	12 words (196 points)	12 words (196 points)
Serial Communication Unit	AFP7NSC	2 words (32 points)	2 words (32 points)	
PHLS master unit	AFP7PHLSM	63 words (1,008 points)	63 words (1,008 points)	

(Note 1) The starting numbers of I/O contacts of each unit including the CPU unit can be changed by the setting of tool software.

(Note 2) As for the PHLS master unit, input occupies 63 words (1,008 points) and output occupies 63 words (1,008 points). The actual input/output points that can be used vary by the number of slave units that are connected, with the maximum of 1,008 points.

3.2 Optional Allocation Using FPWIN GR7

3.2.1 Registration of a Unit to be Used and the Starting Word Number

■ Allocation method

The unit to be used and the starting I/O number are set in the following procedure.



◆ PROCEDURE

1. From the menu bar, select "Option" → "FP7 Configuration" → "I/O map".

The "I/O map" dialog box is displayed.

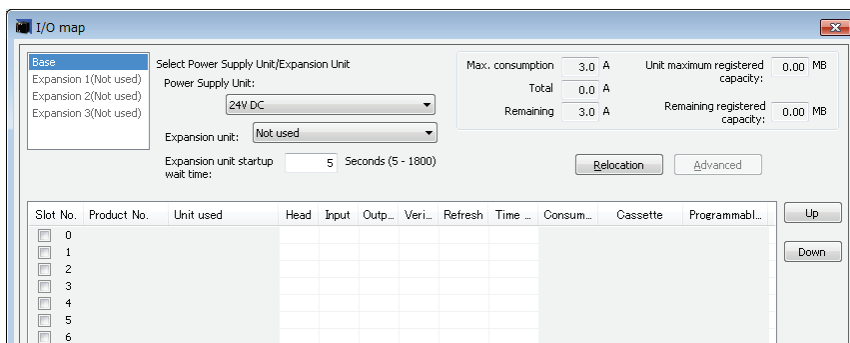

2. Select and double-click Slot No. 0.

The "Unit selection" dialog box is displayed.

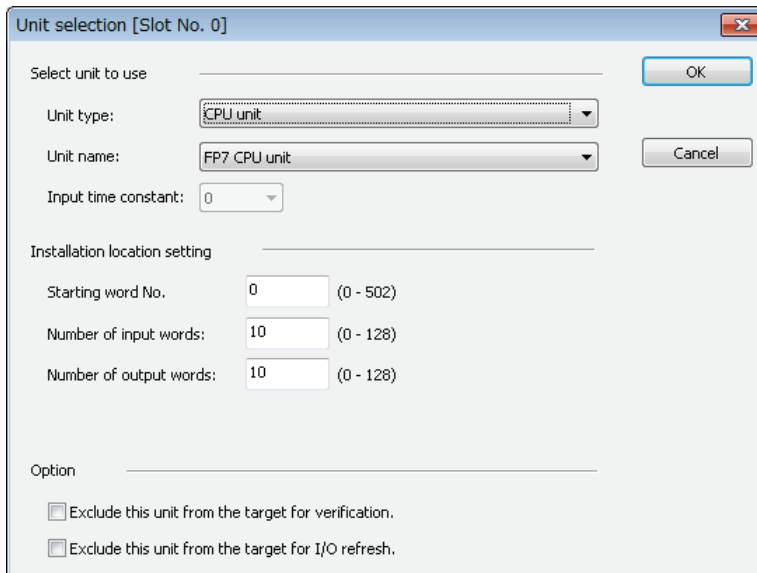

3. Confirm the installation position setting, and press the "OK" button.

The CPU unit is registered in the I/O map. If the CPU unit is different, select "Tool" → "Convert PLC Type" from the menu bar and change the type.

4. Select and double-click Slot No. 1.

The "Unit selection" dialog box is displayed.

5. In the unit type field, select a unit to be attached.

Subsequently, input words and output words are automatically entered.

6. As necessary, enter the starting word number and press the [OK] button.

The registered unit and the starting word number are included in the I/O map. A number that combines the starting word number registered for each unit and 0 to F becomes the starting I/O number.

7. Repeat registrations.

8. Press the [OK] button while the "FP7 configuration" dialog box is displayed.



◆ KEY POINTS

- The I/O map registered using FPWIN GR7 is downloaded into the CPU unit, together with other project information. If a difference with the actual units and/or attachment status is identified when power supply is turned on or during operation, such a difference is reported as a self-diagnosis error.
- If a starting word number is not entered, the system automatically enters one.
- Based on the starting word number allocated to each unit, I/O numbers are allocated.
- The starting number of I/O numbers allocated to the internal functions of the CPU unit can be changed to another number from the word number 0.

3.2.2 Optional Settings in the “Unit Selection” Dialog Box

■ Input time constants

Input time constants for an input unit or a mixed input/output unit can be changed as necessary. Select, and set for each unit, a desirable value from "No settings", 0.1, 0.5, 1.0, 5.0, 10.0, 20.0 or 70.0 ms. The selected time constants are added to the hardware-specific response time of each unit.

For details, please see the "FP7 Digital Input/Output Unit Users Manual".

■ Exclude this unit from the scope of verification.

- In general, this check box should be turned off.
- If you want to exclude this unit from the scope of verification error temporarily for unit replacement or adjustment, turn on this check box.

■ Exclude this unit from the scope of I/O refresh.

- In general, this check box should be turned off. Input/output processing is performed at the timing of I/O refresh in a normal scan.
- By using operation devices "Direct input IN " or "Direct output OT", it becomes possible to directly perform input/output processing during operation, independent of normal I/O refresh. When this operation device is used, turn on the check box "Exclude this unit from the scope of I/O refresh".
- By turning this check box on, all inputs and outputs of registered units are excluded from the scope of I/O refresh.

3.2.3 Settings When Using Expansion Unit

Make the settings according to the used configuration.

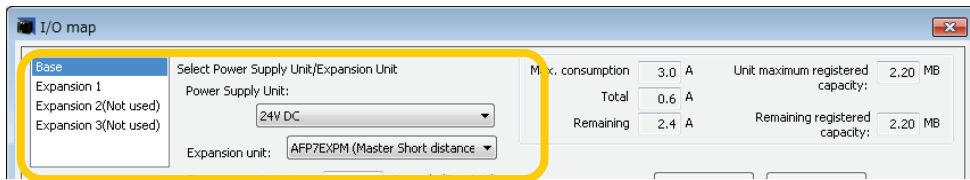

■ Selection of Power supply unit and Expansion unit

Setting item		Description
Common to Base and Expansion 1-3	Power supply unit	Select 24 V DC or a power supply unit according to the used configuration.
Base	Expansion unit	AFPEXPM (Master, short distance): Select when the total length of expansion cables is 9 m or less. AFPEXPM (Master, long distance): Select when the total length of expansion cables is 10 m or more.
Expansion 1-3	Expansion unit	Select AFP7EXPS (Slave).
Common to Base and Expansion 1-3	Expansion unit startup wait time	Set the wait time until the power to the expansion unit turns ON after the power to the CPU unit turned ON. A self-diagnostic error occurs when the power to the expansion unit does not turn on even after the elapse of the startup wait time. Communication via the USB port , COM port and LAN port of the CPU unit cannot be performed during the startup wait time. Setting range: 5 to 1800 secs, Default: 5 secs

3.3 Mount Allocation Using FPWIN GR7

3.3.1 Mount Registration of a Unit to be Used and the Starting Word Number

■ What is mount registration?

If all units to be used are physically at hand, you can connect FPWIN GR7 online to the FP7 CPU unit, read the actual mount status, and complete registration.

■ Allocation method

Mount registration of the unit to be used and the initial I/O number are set in the following procedure.



◆ PROCEDURE

1. **From the menu bar, select "Online" → "Online Editing".**
The screen is switched to the "Online Editing" mode.
2. **Select "Option" → "FP7 Configuration".**
3. **In the relevant field, select "I/O Map".**
The "I/O Map" dialog box is displayed.
4. **Press the [Mount Registration] button.**
The mount status is read, and the read I/O map is registered in the CPU unit.



◆ KEY POINTS

- **Following the mount registration operation, the system automatically reads the unit attachment status, formulates an I/O map, and enters the initial word number.**
- **The I/O map that has been mount-registered using FPWIN GR7 is registered into the CPU unit, together with other project information. If a difference with the actual units and/or attachment status is identified when power supply is turned on or during operation, such a difference is reported as a self-diagnosis error.**
- **If a starting word number is not entered, the system automatically enters one.**
- **Based on the starting word number allocated to each unit, I/O numbers are allocated.**

3.3.2 Changing the Starting Word Number

When you want to change the starting word number following mount registration, please take the following procedure.

■ Allocation method

Changing the starting word number following mount registration should be performed in the following procedure. In the following procedure, it is assumed that an I/O map is already displayed.



◆ PROCEDURE

1. On the "I/O Map", double click a unit for which the starting word number should be changed.

2. Enter a desired starting word number and press the [OK] button.

The changed number is registered in the I/O map.



◆ KEY POINTS

- Once you change the starting word number using FPWIN GR7, the I/O map is changed from the initial status following mount registration. It is necessary to edit the I/O map online, or to download the project once again.
- Pressing the "Reallocate" button with a desired slot selected displays the word No. reallocation dialog box.

3.4 Automatic Allocation

3.4.1 Allocation without Using FPWIN GR7

■ What is automatic allocation?

In cases where optional allocation or mount registration is not performed using FPWIN GR7, the system automatically allocates starting word numbers and I/O numbers in order of attachment of units.

■ Allocation method

Numbers are automatically allocated in order of attachment of units when power supply is turned on.



◆ KEY POINTS

- When automatic allocation is used, the system automatically reads the unit attachment status, and formulates an I/O map, when power supply is turned on.
- If a difference with the actual attachment status is identified during operation from the status when power supply was turned on, such a difference is reported as a self-diagnosis error.
- Based on the starting word number allocated to each unit, I/O numbers are allocated.
- In cases where optional allocation or mount registration has already been performed, and the resulting information is registered in the CPU unit, the system does not perform automatic allocation.
- In cases where configuration data are to be set for input/output units and intelligent units, optional allocation is required.

3.5 I/O Map Registration

3.5.1 I/O Map Registration

■ What is I/O map registration?

This refers to a status where I/O map information is registered in the CPU unit. To register an I/O map, the following methods are available.

- Download an I/O map created through optional allocation using FPWIN GR7 into the CPU unit.
- Perform "mount registration" operation in the online editing mode of FPWIN GR7.

3.5.2 I/O Map Clearance

■ How to clear an I/O map

A registered I/O map can be cleared in the following procedure.



◆ PROCEDURE

1. From the menu bar, select "Option" → "FP7 Configuration".
2. In the relevant field, select "I/O Map".
The "I/O Map" dialog box is displayed.
3. Press [Initialize] button.
The I/O map is initialized.



◆ KEY POINTS

- Once the [Initialize] button is pressed, other configuration information is also deleted.

4

Installation and Wiring

4.1 Installation

4.1.1 Installation Environment and Space

■ Installation environment

Operating environment (Use the unit within the range of the general specifications when installing)

- Ambient temperatures: 0 to +55 °C
- Ambient humidity: 10 to 95%RH (at 25°C, no-condensing)
- Pollution degree 2
- Usable altitude: 2,000m above sea level or lower
- Equipment class: Class 1
- Overvoltage category: II or lower
- Installation location: Inside the control panel

Do not use the unit in the following environments.

- Direct sunlight
- Sudden temperature changes causing condensation
- Inflammable or corrosive gas
- Excessive airborne dust, metal particles or saline matter
- Benzine, paint thinner, alcohol or other organic solvents or strong alkaline solutions such as ammonia or caustic soda
- Direct vibration, shock or direct drop of water.
- Influence from power transmission lines, high voltage equipment, power cables, power equipment, radio transmitters, or any other equipment that would generate high switching surges (100 mm or more)

■ Clearance

- In order to secure clearance for ventilation, ensure that the top and the bottom of the unit are at least 50 mm away from other devices, wiring ducts, etc.

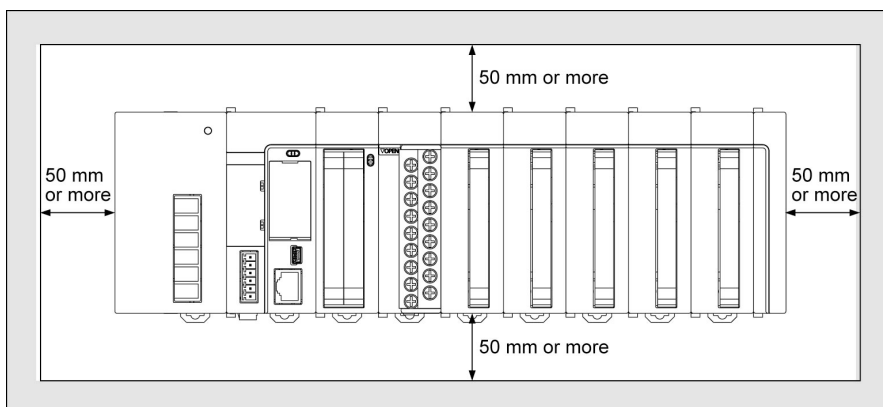

- Do not install the unit stacked up, horizontally or upside down. Doing so will prevent proper cooling of the unit and cause overheating inside.

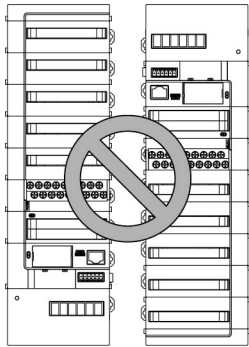

Stacked up installation

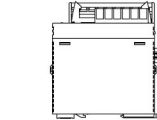

Horizontal installation

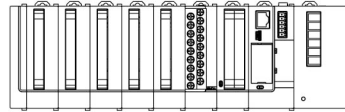
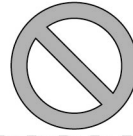

Upside down installation

- Do not install the unit above devices which generate heat such as heaters, transformers or large scale resistors.
- In order to eliminate any effects from noise emission, power wires and electromagnetic devices should be kept at least 100 mm away from the surfaces of the unit. When installing the unit behind the doors of the control board, be especially careful to secure clearances as above.

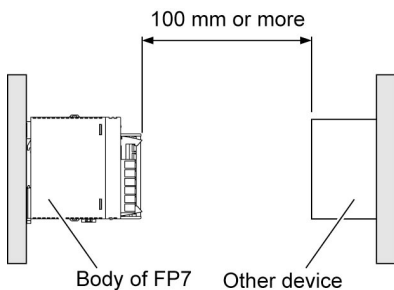

- Secure a clearance of at least 170 mm from the mounting surface of the PLC body for connecting programming tools and cables.

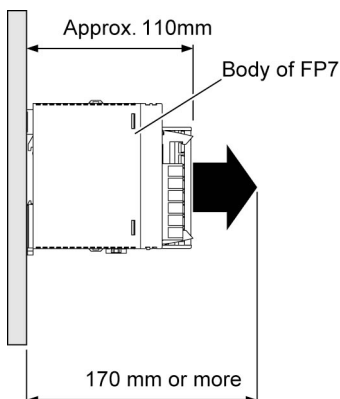

4.1.2 Attaching Units

- Attach unit attachment connectors on the side of each unit.
- Make sure to connect an end unit to the right of the end unit.
- After attaching units, attach the assembly to the DIN rail.

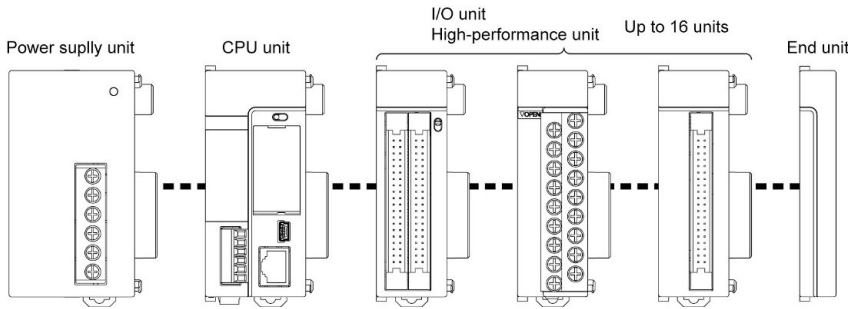

■ Unit attaching procedure

1. Release the fixing hook on the side of the unit.
When attaching a power supply unit, remove the connector cap.

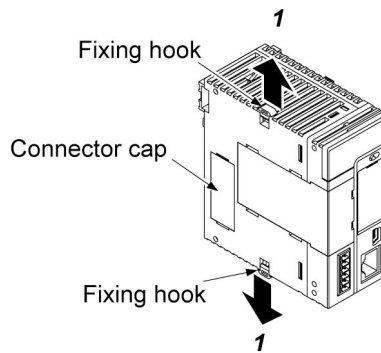

2. Attach unit connectors on the side of each unit.

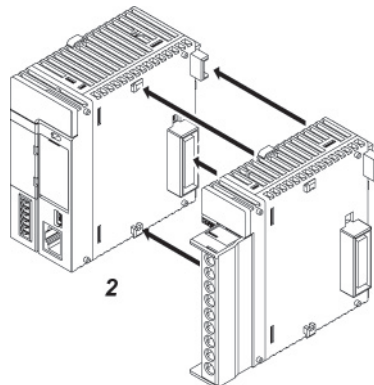

3. Lock the fixing hook.

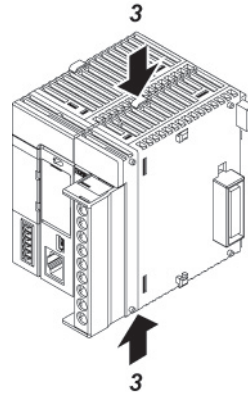

■ Unit removing procedure

1. Release the fixing hook on the side of the unit.

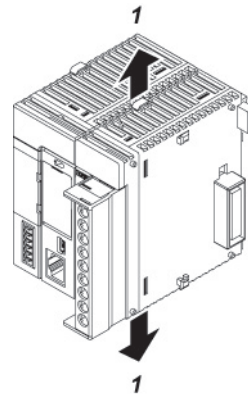

2. Slide the unit horizontally to remove it.

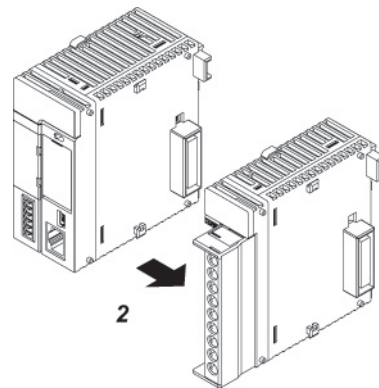

◆ NOTES

- Make sure to turn off power supply before attaching a unit.
- Do not directly touch the connector part of the unit.
- Protect the connector part of the unit from stress.

4.1.3 DIN Rail Attachment

■ **DIN rail attachment procedure**

1. Fully pull out the DIN rail attachment lever on the back of the unit.

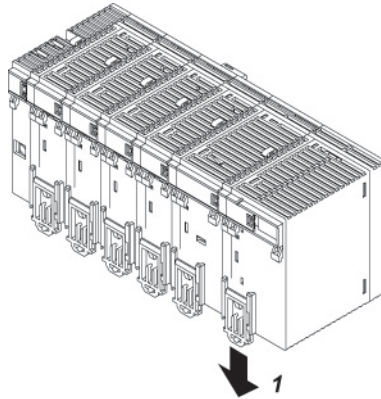

2. Fit the top of the unit attachment part into the DIN rail.
3. While pressing down the unit attachment part onto the DIN rail, fit the bottom of the unit attachment part into the DIN rail.

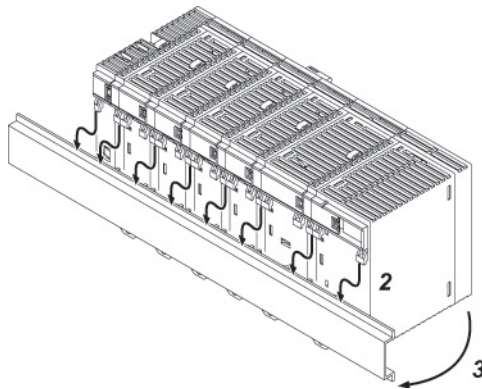

4. Push up the DIN rail attachment lever on the back of the unit until it clicks to lock.

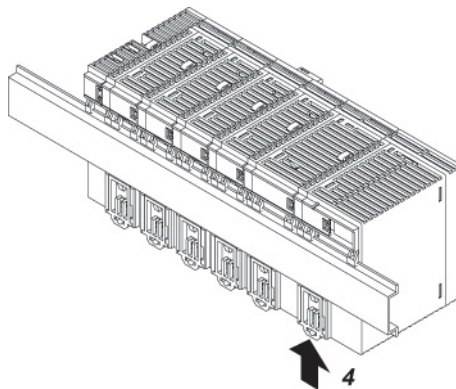

■ **DIN rail removal procedure**

1. Fully pull out the DIN rail attachment lever on the back of the unit.

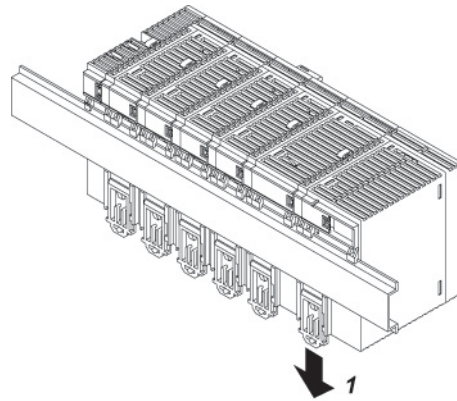

2. Pull the bottom of the unit forward.
3. While pulling up the unit, remove it from the DIN rail.

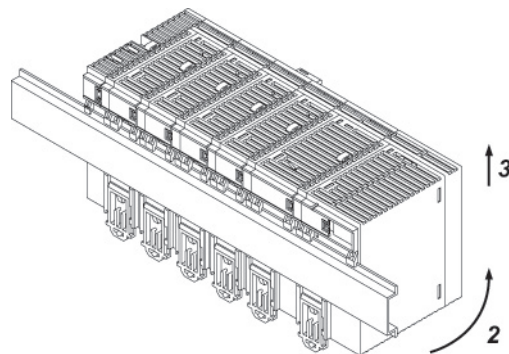

4.2 Wiring the Power Supply

4.2.1 Common Precautions

■ To avoid the influence of noises

- Use a low noise power supply.
- The inherent noise resistance is sufficient for the noise superimposed on the power wires, however, the noise can be attenuated further by using the isolation transformer.
- Also, twist the power supply cables to minimize adverse effects from noise.

■ Keep the power supply wiring separate

Wiring to the CPU unit, input devices, and power equipment should have separate wiring systems.

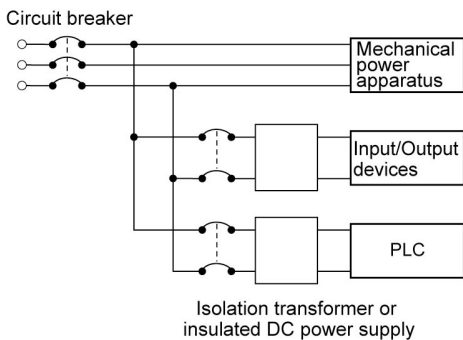

■ Measures regarding power supply sequence (start up sequence)

- Have the power supply sequence such that the power supply of PLC turns off before the power supply for input and output.
- If the input/output power supplies are turned off before the power PLC, the CPU unit will detect the input fluctuations and may begin an unscheduled operation.

4.2.2 Wiring for Power Supply Units

■ Terminal layout for power supply units

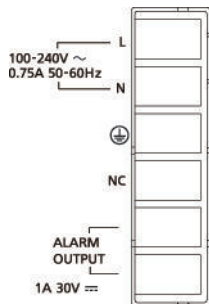

■ Power supply voltage

Confirm that the connected voltage is within the allowable range of the power supply.

Model number	Rated input voltage	Allowable voltage range	Rated output capacity	Rated output current
AFP7PSA1	100 to 240 V AC	85 to 264 V AC	24 W	1 A
AFP7PSA2	100 to 240 V AC	85 to 264 V AC	43 W	1.8 A

■ Power supply cable

Use a power supply wire of 2mm² (AWG14) to minimize the voltage drop.

■ Suitable wires and tightening torque

Terminal	Suitable wires	Tightening torque
Power supply terminal and ground terminal	AWG14 (2.0 mm ²)	0.5 to 0.6 N·m
Alarm output terminal	AWG22 to 14 (0.3 mm ² to 2.0 mm ²)	

■ Suitable crimp terminal

M3 terminal screws are used for the terminal. Use the following solderless terminals for wiring to the terminals.

Fork type terminals

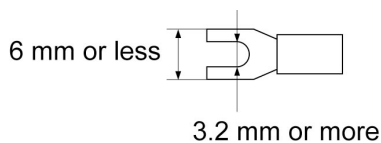

Round type terminal

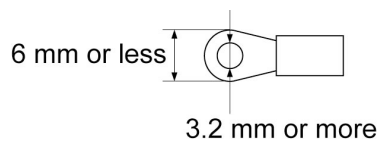

■ Suitable crimp terminal

Manufacturer	Shape	Part no.	Suitable wires
J.S.T. Mfg Co.,Ltd	Round type	2-MS3	1.04 to 2.63 mm ²
	Fork type	2-N3A	
	Round type	1.25-MS3	0.25 to 1.65 mm ²
	Fork type	1.25-B3A	

4.2.3 Wiring for the Power Supply Part of the CPU Unit

- When the CPU unit is used with 24V DC power supply, perform wiring for power supply as follows.
- Use the power supply cables (Part No.:AFPG805) that come with the unit to connect the power supply.
Brown: 24V DC, Blue: 0V, Green: functional earth

■ Power supply part of the CPU unit

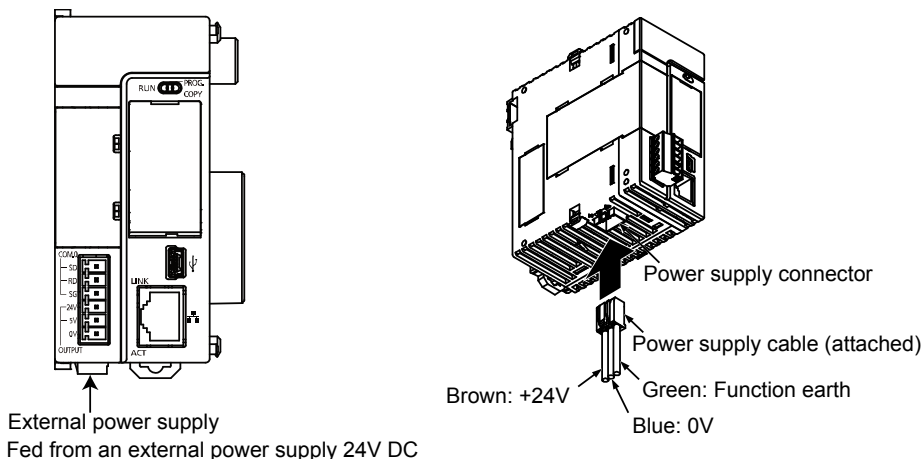

■ Power supply voltage

- Confirm that the power supply voltage is within the allowable range of the power supply.

Rated input voltage	Allowable voltage range	Rated output capacity
24V DC	20.4 to 28.8 V DC	At least 24 W

- When a programmable display GT series is connected to the GT power supply terminal (24V) of the CPU unit, use it within the range of 21.6 to 26.4 V DC.

■ Selection of a power supply

- Referring to Section 1.2, select a power supply larger than the capacity of the unit.
In the minimum configuration, select a power supply of 24 W or larger.
- In order to protect the unit against abnormal voltage from the power supply line, the power supply should be an insulated type, and should be enclosed within a protective circuit. The regulator on the unit is a non-insulated type.
- If using a power supply device without an internal protective circuit, always make sure power is supplied to the unit through a protective element such as a fuse.

4.2.4 Wiring of Power Supply Part of Expansion Slave Unit

When the power supply unit is not used, make the wiring for the power supply as well as the CPU unit with the power supply cable attached to AFP7EXPS.

4.2.5 Grounding

- Ground the instrument to ensure sufficient noise suppression.
- The point of grounding should be as close to the PLC as possible. The ground wire should be as short as possible.
- Sharing the ground with another device may have an adverse effect. Therefore, be sure that grounding is dedicated.
- Earth terminals for an AC power supply unit should be grounded at a grounding resistance of 100 Ω or less.
- When 24V DC is directly supplied to the CPU unit, install the attached functional earth (Green).

 CORRECT

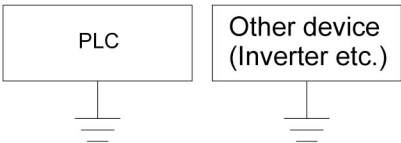

 INCORRECT

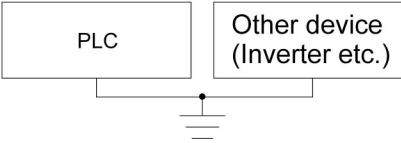

4.3 Wiring of Expansion Cable

4.3.1 Expansion Cable Type

Use the expansion cable AFP7EXPC** (sold separately) for connecting the expansion master unit AFP7EXPM and expansion slave unit AFP7EXPS, or connecting the expansion slave units AFP7EXPS together.

Model number	Cable length
AFP7EXPCR5	0.5 m
AFP7EXPC01	1 m
AFP7EXPC03	3 m
AFP7EXPC10	10 m

4.3.2 Connection of Function Earth Wire

- A function earth wire is attached to the expansion cable. In order to avoid influence of noise, the function earth wire of the expansion cable must be grounded.
- Make grounding as the same as that of the expansion block to which the connector with the function earth wire is connected.

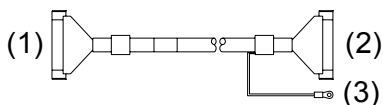

(1)	OUT side	Connected to the OUT side of the expansion master unit AFPEXPM or expansion slave unit AFPEXPS.
(2)	IN side	Connected to the IN side of the expansion slave unit AFPEXPS.
(3)	Function earth wire	Make grounding as the same as that of the expansion block to which the connector with the function earth wire is connected.

- Do not use the expansion cable in the same raceway as other cables are placed.

4.3.3 Connecting Position and Direction of Expansion Cables

- The expansion cable is connected to the MIL connector of the expansion master unit AFP7EXPM and the MIL connector on the IN side of the expansion slave unit AFP7EXPS.
- For adding the expansion block, remove the dummy connector on the OUT side of the expansion slave unit AFP7EXPS, and connect the expansion cable to the MIL connector on the IN side of the expansion slave unit AFP7EXPS in the block to be added.
- Connect the connector with the function earth wire to the MIL connector on the IN side of the expansion slave unit AFP7EXPS.
- Do not use the expansion cable in the same raceway as other cables are placed.

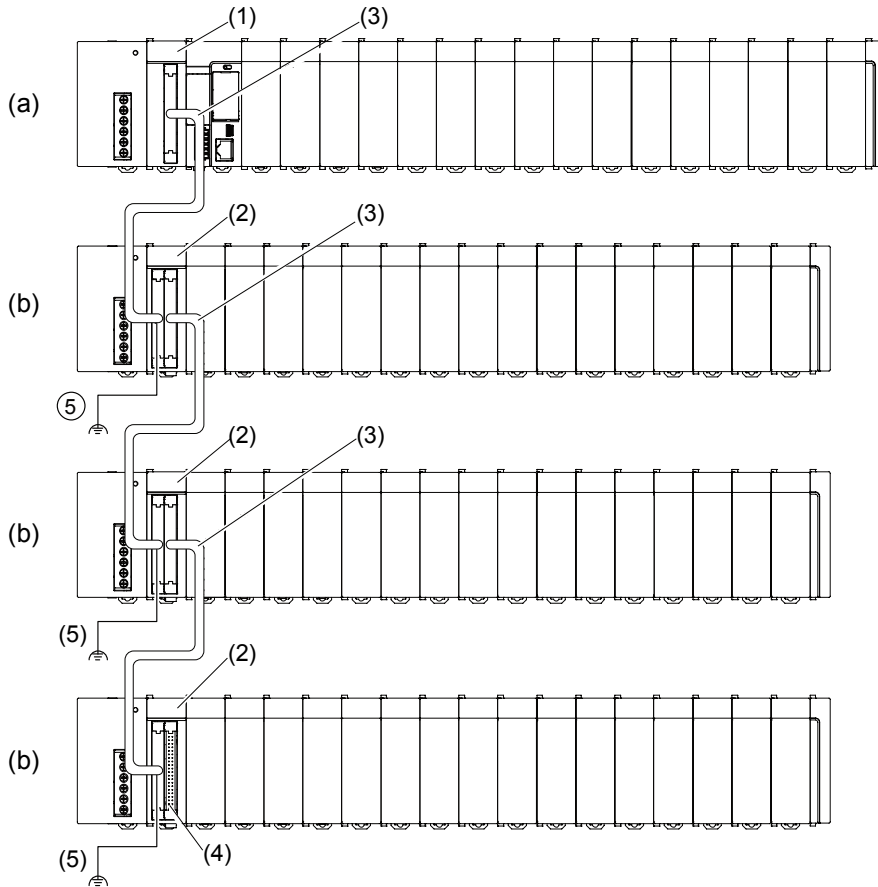

(a)	Base block	(1)	Expansion master unit	(3)	Expansion cable	
(b)	Expansion block	(2)	Expansion slave unit	(4)	Dummy connector	(5) Earth wire of expansion cable

4.4 Safety Measures

4.4.1 Safety Circuit

■ Precautions regarding system design

- In certain applications, malfunction may occur for the following reasons:
 - Power on timing differences between the PLC system and input/output or mechanical power apparatus.
 - Response time lag when a momentary power drop occurs.
 - Abnormality in the PLC unit, external power supply, or other devices.

In order to prevent a malfunction resulting in system shutdown take the following measures as adequate:

■ Install the interlock circuit outside PLC

- When a motor clockwise/counter-clockwise operation is controlled, provide an interlock circuit externally.

■ Install the emergency stop circuit outside PLC

- Install an emergency stop circuit outside PLC to turn off power supply to the output device.

■ Start up other devices before PLC

- The PLC should be started after booting the I/O device and mechanical power apparatus.
- When stopping the operation of PLC, have the input/output devices turned off after PLC has stopped operating.

■ Install safety measures in case of alarm outside the PLC body

- When an alarm is released, PLC output is turned off and its operation is stopped. In order to prevent a malfunction resulting in system shutdown under the above conditions, install safety measures outside PLC.

■ Perform secure grounding

- When installing PLC next to devices that generate high voltages from switching, such as inverters, do not ground them together. Use an exclusive ground for each device which should be grounded at a grounding resistance of 100 Ω or less.

4.4.2 Momentary Power Drop

Operation in the case of momentary power drop varies depending on the combination of units, the power supply voltage, and other factors. In some cases, operation may be the same as that for a power supply reset.

- When a power supply unit (AC) is being used, operation is continued in the case of momentary power drop shorter than 10 ms.
- When 24V DC is being supplied to the CPU unit, operation is continued in the case of momentary power drop shorter than 4 ms.

4.4.3 Alarm Output

- A power supply unit has an alarm output contact that can be used for releasing alarm signals to outside in the event of error.
- The relay contact for alarm output is closed when power supply is ON. If the watchdog timer is operated due to a hardware error or a program error, the relay contact is turned into an open status.

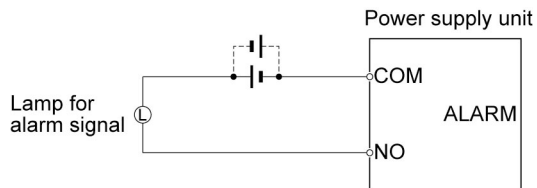

- The watchdog timer is a program error and hardware error detection timer.
- When the watchdog timer is operated, the ALARM LED in the front of the controller unit turns on. In cases where a power supply unit is attached, the ALARM contact of the power supply unit is operated at the same time. All outputs to the output units are turned off and the unit is put in halted state. In the meantime, no processing is undertaken at all, and communication with the programming tool is also halted.

5

Operation

5.1 Before Powering On

5.1.1 Check Points

Once wiring has been completed, check the following points before powering on.

■ Check Points

	Items	Description
1	Attaching Units	<ul style="list-style-type: none">• Does the product name match the device list during the design stage?• Are the unit mounting screws properly tightened? Is there any looseness?• Has the dust-proof sheet been removed from the unit?
2	Wiring	<ul style="list-style-type: none">• Are the terminal screws properly tightened? Is there any looseness?• Does the wiring of terminal match the signal name?• Does the wiring have sufficient thickness for expected current?
3	Connecting cables	<ul style="list-style-type: none">• Is the cable securely connected?• Are the connection cables properly connected?
4	Settings of CPU	<ul style="list-style-type: none">• Is the mode switch set to "PROG."?• Are settings for the card operation switch correct?
5	Others	<ul style="list-style-type: none">• Carefully check if there is any potential for an accident.

5.1.2 Procedures before Starting Operation

Procedures following installation and wiring and before starting operation are as follows.

1. Powering on

- (1) Before powering on, carry out a check referring to "5.1.1 Check Points".
- (2) After powering on, check that the POWER LED (Blue) and PROG. LED (Green) are ON on the CPU unit. When a power supply unit is to be used, check that the power supply unit's POWER LED is ON.



2. Entering a project

- (1) Create a project using the programming tool software.
- (2) Use the programming tool's "total check function" to check for syntax errors.



3. Checking output wiring

Use the forced I/O function to check the output wiring.



4. Checking input wiring

Check the input wiring by using the input display LEDs or the monitoring function of the programming tool.



5. Trial operation

- (1) Set the mode switch to "RUN" and check that the "RUN" LED is turned on.
- (2) Check the sequence operation.



6. Debugging

- (1) If there is an error in the operation, check the project using the monitoring function of the programming tool.
- (2) Correct the project.



7. Saving the project

Save the created project.

5.2 RAM/ROM Operation

5.2.1 Transmission of the Project

Set the mode switch to "PROG". Check that the card operation switch is set to "ROM", and subsequently power on the unit.

■ **Switch setting conditions**

Switch	Setting
Mode switch	PROG.
Card operation switch	ROM

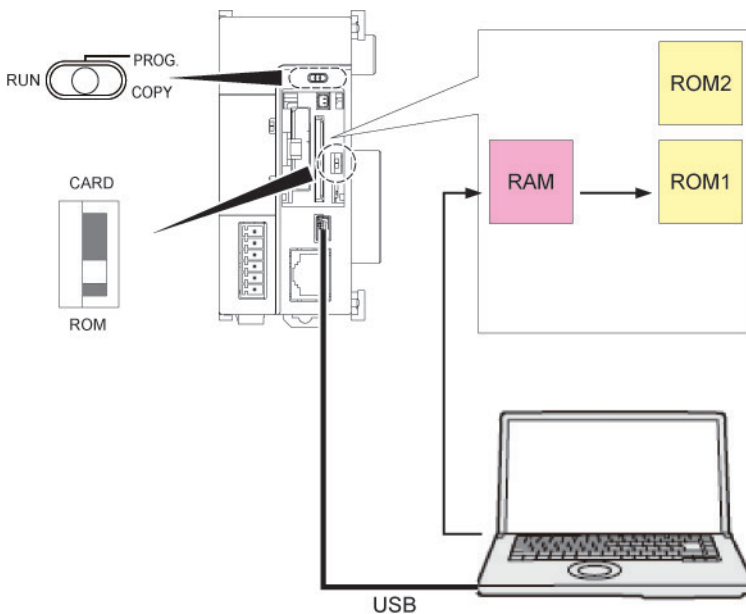

■ **Procedure**

1. Set the mode switch to PROG.
2. Set the card operation switch to ROM.
3. Power on the unit.
4. Download the project from the PC to FP7.
The downloaded data is saved in the built-in RAM, and is also automatically saved in the ROM.

5.2.2 Operations following Powering On

When the unit is powered on, whether in the PROG. mode or in the RUN mode, the project is transmitted from ROM1 to RAM.

■ Switch setting conditions

Switch	Setting
Mode switch	PROG. or RUN
Card operation switch	ROM

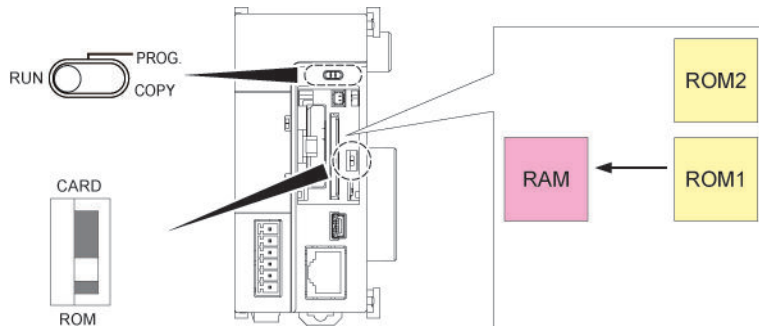

■ Procedure

1. The execution project is automatically transmitted from ROM1 to RAM.
2. In the RUN mode, operation is started.

5.2.3 Data Hold During Power Failure

The FP7 CPU unit backs up most data into ROM (non-volatile memory).

■ Data saved in ROM (non-volatile memory)

- Project data (programs, configuration data, comments)
- Hold type data in the operation memory
- System monitors, system records data (e.g. lifetime data, error records)

■ Data held by the built-in capacitor and the backup battery

- Calendar timer



◆ KEY POINTS

- **Calendar timer values can continue operation for about one week by the built-in capacitor, even if no battery is used.**
- **In order to charge the built-in capacitor, supply power to the CPU unit for at least 30 minutes.**

5.2.4 Online Editing

The FP7 CPU unit can be edited online. Usable operations vary by mode.

■ PROG. mode

- While editing a program, the program inside the RAM is rewritten by PG converting a given network inside the program block that is being edited.
- Rewritten data in the RAM is incorporated into the ROM1.
- Comments and configuration data can also be rewritten.

■ RUN mode

- While editing a program, the program is written into the RAM by PG converting a given network inside the program block that is being edited.
- Rewritten data in the RAM is incorporated into the ROM1.
- Configuration data cannot be rewritten.
- Comments can be rewritten.
- It is not possible to download the entire project.
- It is possible to download the Program Block (PB).

After a program is rewritten in the RUN mode, operation stops for a time length proportionate to the size of the relevant PB.

5.3 Backing Up the Project

5.3.1 Transmission from the Execution Memory RAM to the Backup Memory ROM2

In normal operation, you can save your project in the execution memory RAM/ROM1, and use the saved data. In order to prepare for unplanned rewriting, backup memory ROM2 is also installed.

When the mode switch is set to PROG., you can back up the execution project that is saved in RAM into ROM2.

■ Switch setting conditions

Switch	Setting
Mode switch	PROG.
Card operation switch	ROM

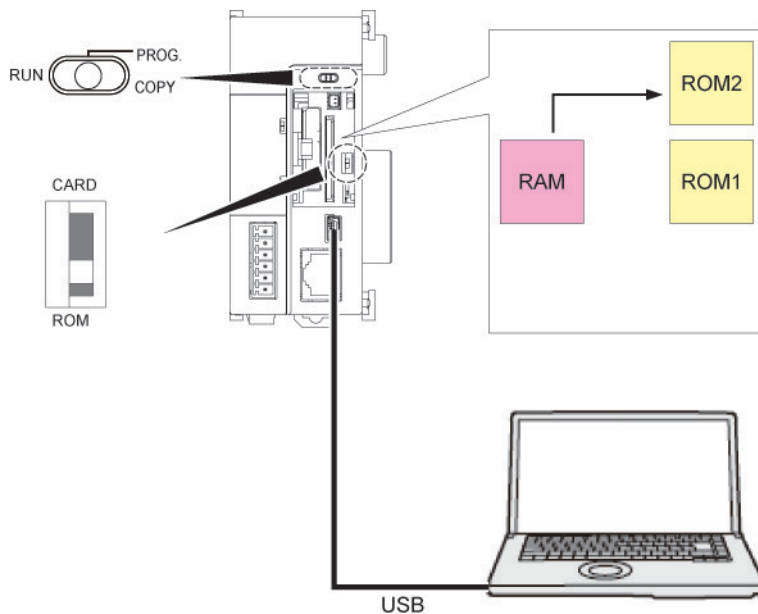

■ Procedure

1. Set the mode switch to PROG.
2. By executing "Online" → "Project Backup" using FPWIN GR7, the project is transmitted from the execution memory RAM to the backup memory ROM2.

5.3.2 Transmission from the Backup Memory ROM2 to the Execution Memory RAM/ROM1

It is possible to transmit the backup project saved in ROM2 to RAM/ROM1 to be used as an execution project.

■ Switch setting conditions

Switch	Setting
Mode switch	PROG.
Card operation switch	ROM

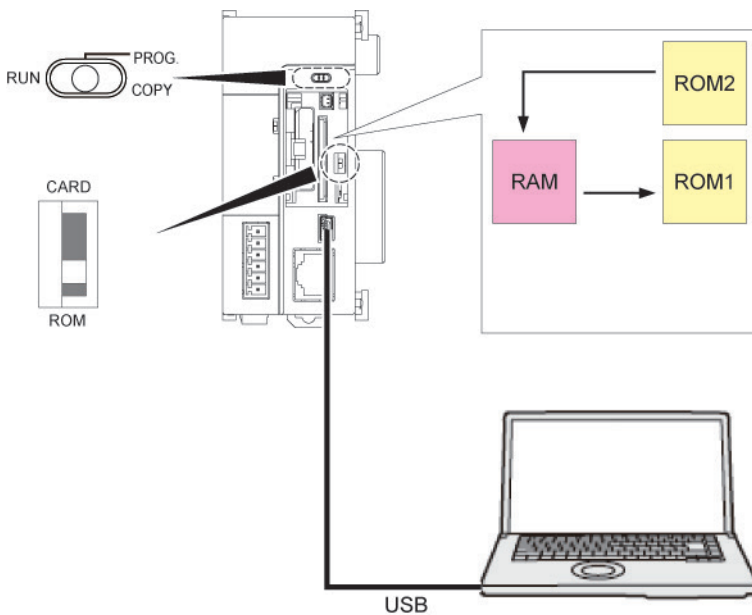

■ Procedure

3. Set the mode switch to PROG.
4. By executing "Online" → "Project Restore" using FPWIN GR7, the project is transmitted from the backup memory ROM2 to the execution memory RAM.
5. The project data is also automatically transmitted from RAM to ROM1.

5.3.3 Operations following Powering On/Off

Powering the unit on or off does not affect data saved in the backup memory ROM2.

5.4 SD Memory Card Operation

5.4.1 Preparing SD Memory Cards

■ Usable SD memory cards

Use of Panasonic SD memory cards (for industrial use) is recommended.

(Note) An operation check has not been conducted for SD memory cards made by other manufacturers.

Logo printed on the CPU unit	Usable SD memory cards	
	Card type	Capacity
	SD memory card	2GB
	SDHC memory card	4GB to 32GB

■ Cautions on handling an SD memory card

The data saved in the SD memory card may be lost in the following cases. We assume no responsibility whatsoever for the loss of saved data.

- The user or a third party has misused the SD memory card.
- The SD memory card has been affected by static electricity or electric noise.
- The SD memory card was taken out, or the PLC body was powered off, while the card was being accessed (e.g. saving data into the card, deleting data from the card).

■ Formatting of SD memory cards

In principle, SD memory cards have been formatted by the time of purchase, and no formatting by the user is required. If formatting becomes necessary, download formatting software for SD memory cards on the following website.

SD Association's website

<https://www.sdcard.org/home/>



◆ NOTES

- **A file system formatted by PC's standard formatting software does not satisfy the SD memory card specifications. Please use the dedicated formatting software.**
It is recommended to save important data in another media for backup. Never remove the card or power off the PLC body while the SD LED on the CPU unit is flashing (data is being read from or written into the card). Data may be damaged.
- **Do not use a SD memory card with the memory capacity of which is more than the usable capacity. Data in the card may be damaged.**

5.4.2 How to Insert an SD Memory Card

Take the following procedure to insert an SD memory card.

■ Procedure

1. Open the card cover on the surface of the CPU unit.

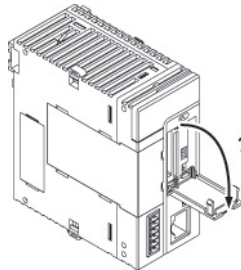

2. Press in an SD memory card into the SD memory card slot until it locks.

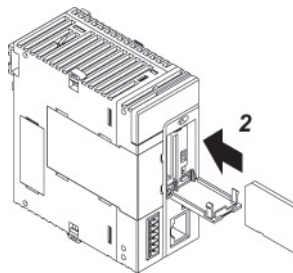

3. Close the SD memory card cover.

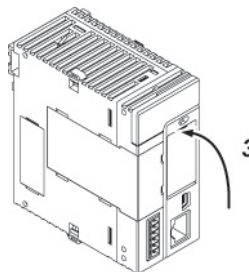

◆ KEY POINTS

- If the card cover is opened during access to the SD memory card while the CPU unit is operating, a self-diagnosis error is detected and operation is stopped. Access to the SD memory card is also stopped.
- Before removing an SD memory card, confirm that the operation monitor LED [SD] on the CPU unit has been turned off.

5.4.3 Saving an Execution File for SD Memory Card Operation

In order to enable operation by an SD memory card, it is necessary to convert the created project into an auto execution file. Take the following procedure.



◆ PROCEDURE

1. Create an "AUTO" folder in an SD memory card.
2. From the menu bar, select "Tools" → "SD Memory Card" → "Create an Auto Execution File".
The "Browse Folders" dialog box is displayed.
3. Select the "AUTO" folder created in Step 1, and press the [OK] button.
An auto execution file "autoexec.fp7" and a comment file "comment.fp7" are created.

5.4.4 Provisional Operation by an SD Memory Card

■ **Provisional operation of a project saved in an SD memory card**

Insert an SD memory card, set the mode switch to "RUN", and set the card operation switch to "CARD" to enable provisional operation of a project saved in the card.

■ **Switch setting conditions**

Switch	Setting
Mode switch	RUN
Card operation switch	CARD

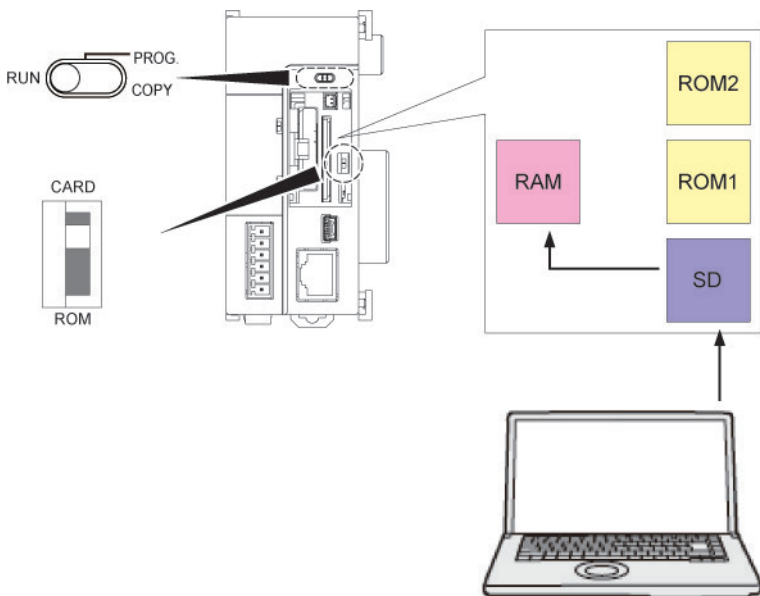

■ **Procedure**

1. Power off the unit.
2. Attach an SD memory card that houses the auto execution file "autoexec.fp7" and the comment file "comment.fp7", a project to be used for provisional operation, to the CPU unit.
3. Set the card operation switch to "CARD".
4. Close the cover and power on the unit.
The auto execution file "autoexec.fp7" and the comment file "comment.fp7", a project saved in the SD memory card, is transmitted to the execution memory RAM. Transmission of the project takes place when the unit is powered on or the mode switch is set to "RUN".

■ Operations during SD Memory Card Operation

If the following steps are taken, the unit runs in the "SD memory card operation" mode. Until the unit is powered off, it cannot be switched into RAM/ROM operation.

Example 1:

- 1) Power on the unit while the card operation switch is set to "ROM".
- 2) Set the card operation switch to "CARD".
- 3) Set the mode switch to "RUN".

Example 2:

- 1) Power on the unit while the card operation switch is set to "CARD".
- 2) Set the mode switch to "RUN".



◆ KEY POINTS

- The online editing functions is not usable ("protect error").

5.4.5 Transmission from an SD Memory Card to the Execution Memory

Insert an SD memory card, and set the mode switch to "COPY", in order to transmit a project saved in the SD memory card to ROM1 and write it in as an execution project.

■ **Switch setting conditions**

Switch	Setting	
	OFF	ON
Mode switch	RUN→COPY	PROG.→COPY
Card operation switch	CARD	ROM→CARD

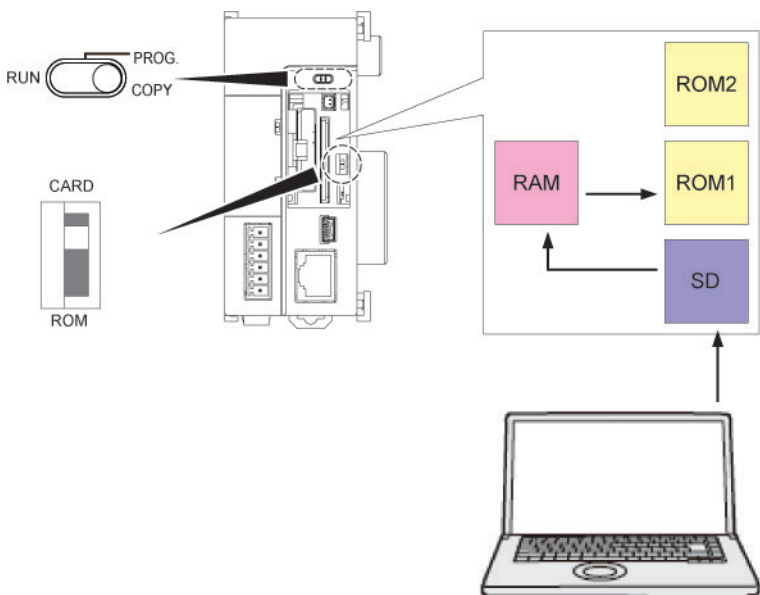

■ **When power is OFF**

1. Attach an SD memory card that houses the auto execution file "autoexec.fp7" and the comment file "comment.fp7" for a project to the CPU unit.
2. Close the cover and power on the unit.
3. Until "COPY LED" flashes (approx. 5 seconds), set the RUN/PROG./COPY switch to "COPY".
Transmission of project data is started. Once "COPY LED" starts to flash, the transmission process continues if you let go off the COPY switch. Once transmission is completed, "COPY LED" turns off.

■ When power is ON

1. Change to the PROG. mode.
2. Attach an SD memory card that houses the auto execution file "autoexec.fp7" and the comment file "comment.fp7" for a project to the CPU unit.
3. Close the cover.
4. Until "COPY LED" flashes (approx. 5 seconds), set the RUN/PROG./COPY switch to "COPY".

Transmission of project data is started. Once "COPY LED" starts to flash, the transmission process continues if you let go off the COPY switch. Once transmission is completed, "COPY LED" turns off.



◆ KEY POINTS

- **Copying of a project triggered by the COPY switch does not depend on settings for the card operation switch. Operation starts whether the switch is set to CARD or ROM.**

5.4.6 Precautions Concerning SD Memory Card Operation

- In an SD memory card to be used, create an "AUTO" folder, and save an auto execution file "autoexec.fp7" and a comment file "comment.fp7".
- While the card project regular operation mode LED [COPY] (Green) is on, do not remove the SD memory card from the slot. It may cause damage to the project.
- If the card operation switch is set to "CARD" while no SD memory card is inserted, a self-diagnosis error will result.
- If the unit cannot access a project in the SD memory card while the card operation switch is set to "CARD" and SD memory card operation is in progress, a self-diagnosis error will result.

5.5 Operation When Using Expansion Master Unit/Slave Unit

5.5.1 Operation When Power Supply Turns ON/OFF

■ Sequence of turning ON/OFF the power supply

- The power supply should be turned on or off in the following sequence.

Item	Sequence
When turning on power	Power supply for I/O device → Expansion block (Expansion slave unit) → Base block (CPU unit)
When turning off power	Base block (CPU unit) → Expansion block (Expansion slave unit) → Power supply for I/O device

■ Operation when the power to the base block turns off during operation

- If the power supply to the base block (CPU unit) turns off during operation, the expansion block will stop the operation. At this time, the output of the units attached to the expansion block will be turned OFF.
- If the power to the base block is turned on when the power to the expansion block is on, the system will be rebooted.

■ Operation when the power to the expansion block turns off during operation

- If the power to the expansion block (expansion slave unit) turns off during operation, a self-diagnostic error will occur and the CPU unit will stop. Other expansion blocks will also stop.
- Operation will not restart even if the power to the expansion block turns on again when the CPU stops due to the error. If the power to the base block is turned on when the power to all the expansion blocks is on, the system will be rebooted.

5.5.2 Insertion and Removal of Expansion Cable

- Do not insert or remove the expansion cable when the power is on.
- The whole system operation will stop if the expansion cable is removed during operation. Even if the cable is inserted again during operation, the operation will not restart.

6

Troubleshooting

6.1 Self-Diagnosis Function

6.1.1 CPU Unit's Operation Monitor LED

The CPU unit has a self-diagnostic function which identifies errors and stops operation if necessary. Indications concerning self-diagnosis are as follows.

■ LED indications concerning self-diagnosis errors

	LED indications on the CPU unit				Description	Operation status
	RUN Green	PROG Green	ERROR Red	ALARM Red		
Normal operation	●	○	○	○	Normal operation	Operation
	○	●	○	○	PROG. mode	Stop
	▲	○	○	○	Forcing input/output in the RUN mode	Operation
Error	●	○	▲	○	When a self-diagnostic error occurs (Operation)	Operation
	○	●	▲	○	When a self-diagnostic error occurs (Stop)	Stop
	○	●	—	●	System watchdog timer has been activated	Stop
	○	▲	—	○	Waiting for connection of the PHLs slave	Stop

(Note) ●: ON, ▲: Flashing, ○: OFF, -: Varies (ON or OFF)

6.1.2 Operation at the Time of Error

Normally, when an error occurs, the operation stops.

■ Configuration menu of FPWIN GR7

Operation mode of the CPU unit at the time of error can be set (Continue or Stop) in the "FP7 Configuration" menu of the tool software FPWIN GR7.

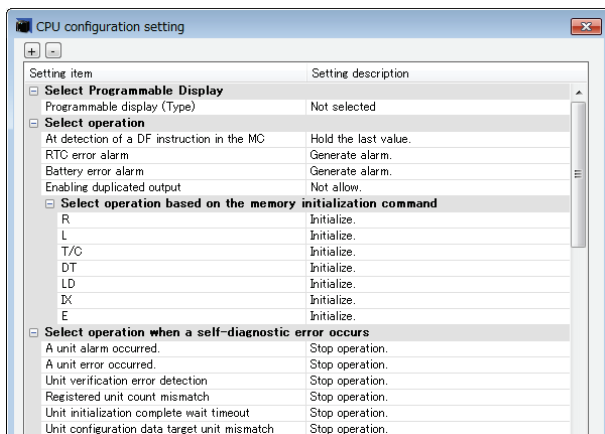

CPU configuration

6.2 What to Do If an Error Occurs

6.2.1 ERROR LED Flashes on the CPU Unit

■ Condition

A self-diagnostic error has occurred.

■ Solution

Confirm the status in the following procedure.



◆ PROCEDURE

1. Select "Online" → "Status Display" in FPWIN GR7, and check the error details (error code).
2. Switch to the PROG. mode.
3. If a self-diagnosis error other than syntax error has occurred, cancel the situation in accordance with the error code.
4. In the case of a syntax error, use the "Totally Check Project" function under "Debug" in FPWIN GR7 to identify the syntax error.



◆ KEY POINTS

- In the case of an operation error, check the address where the error occurred before performing error clearance.
- In the case of an error coded 80 or higher, the error can be cleared by pressing the [Error Clearance] button in the "Status Display" dialog box.
- In the PROG. mode, the power supply can be turned off and then on again to clear the error, but all of the contents of the operation memory except hold type data are cleared.
- An error can also be cleared by executing a self-diagnostic error set instruction (ERR).

6.2.2 PROG Mode Does Not Change to RUN

■ **Condition:**

A syntax error or a self-diagnosis error that caused operation to stop has occurred.

■ **Solution:**

Confirm the status in the following procedure.



◆ **PROCEDURE**

1. Confirm that the **ERROR** or **ALARM LED** is not turned on.
2. Use the "Totally Check Project" function under "Debug" in **FPWIN GR7** to identify the syntax error.

6.2.3 ALARM LED Turns ON on the CPU Unit

■ **Condition:**

The system watchdog timer has been activated and the operation of controller has been stopped.

■ **Solution:**



◆ **PROCEDURE**

1. Switch the CPU unit to the **PROG. mode**, and turn off the power supply and then on again.

If the **ALARM LED** lights again, there may be a problem with the unit. If the **ALARM LED** goes out after the power supply is turned off and then on again, the problem may have been caused by noise or another temporary phenomenon.

2. Switch to the **RUN mode**.

If **ALARM LED** turns on after switching to the **RUN mode**, the program is taking excessive time. Review and modify the program.

3. Check the ambient environment for influence of noise.

If there is no problem with the program, there may be a problem in the ambient environment. Check the wiring including the earth wiring. In particular, check if the **RS-232C** wiring is not close to power cables, and if the wiring is shielded.



◆ **KEY POINTS**

- When the program is to be reviewed, check the following points.
Example 1: Is there any infinite loop in the program, resulting from a **JP** instruction, **LOOP** instruction or other instructions that control the program flow?
Example 2: Are there multiple interrupt instructions that are being consecutively executed?

6.2.4 POWER LED Does Not Turn ON on the Power Supply Unit

■ **Condition:**

It is possible that sufficient power is not supplied.

■ **Solution:**

Confirm the status in the following procedure.



◆ **PROCEDURE**

1. **Power off the unit and double-check the wiring status (e.g. Is there any loose terminal?)**

2. **Check if output of the power supply unit exceeds the rating.**

If capacity of the internal power supply (24V) does not suffice, examine changing combination of the units.

3. **Disconnect the power supply wiring to the other devices if the power supplied to the unit is shared with them.**

If LED on the power supply unit turns on following the above step, undercapacity of power supply is possible. Review the power supply design.

6.2.5 A Protect Error Message Appears

■ **Condition:**

It is possible that the project is password locked.

■ **Solution:**

Confirm the status in the following procedure.



◆ **PROCEDURE**

1. **Select "Tools" → "Register/Delete Password" in FPCWIN GR7.**

The "Register/Delete Password" dialog box is displayed.

2. **Enter a password and press the [OK] button.**

The protection is canceled.



◆ **KEY POINTS**

- **If you press the [Forced Cancellation] button, all projects saved in PLC are deleted.**

6.2.6 If Expected Output Is Not Available

■ Condition:

Both software reasons (e.g. program, I/O allocation) and hardware reasons (e.g. wiring, power supply) are possible.

■ Solution (check of the output side)

Proceed from the check of the output side to the check of the input side.



◆ PROCEDURE

1. Check if output indication LED on the input/output units is on.

If it is on, proceed to the next step. If it is not, proceed to Step 4.

2. Check the wiring of the load (e.g. Is there any loose terminal?)

If LED on the unit turns on following the above step, undercapacity of power supply is possible. Review the power supply design.

3. Check if the power is properly supplied to both ends of the load.

If the power is properly supplied to the load, there is probably an abnormality in the load. If the power is not supplied to the load, there is probably an abnormality in the output section.

4. Monitor the output status using the tool software FPWIN GR7.

If the output monitored is turned on, there is probably a duplicated output error, etc.

5. Forcibly turn on and off the relevant output using the forced input/output functions of the tool software FPWIN GR7.

If the output indicator LED of the units is turned on, go to input condition check. If the output indicator LED remains off, there is probably an abnormality in the unit's output part.

■ Solution (check of the input side)

Clarify the situation in the following procedure.



◆ PROCEDURE

1. Check whether the input indication LED on the unit is ON.

If it is OFF, proceed to the next step. If it is, proceed to Step XX.

2. Check the wiring of the input device (e.g. Is there any loose terminal?)

If LED on the unit turns on following the above step, undercapacity of power supply is possible. Review the power supply design.

3. Check that the power is properly supplied to the input terminals.

If the power is properly supplied to the input terminals, there is probably an abnormality in the unit's input part. If the power is not supplied to the input

terminal, there is probably an abnormality in the power supply or the input device.

4. Monitor the input status using the tool software FPWIN GR7.

If the input monitored is off, there is probably an abnormality with the unit's input part.

Modify the program if the input monitored is on. If the input device is a two-wire sensor, influence of leaked current is possible.



◆ KEY POINTS

- **When the program is to be reviewed, check the following points.**
 1. Check if output specifications are rewritten (e.g. duplicated output use)
 2. Check if the program flow has been changed due to an MCR instruction, JMP instruction or other control instructions.
 3. Check if the I/O map allocation agrees with the actual mount status.

6.2.7 ERR LED Turns ON on the Expansion Unit

■ Condition

There is probably an error in the power supply system of the expansion block in which the expansion slave unit with the ERROR LED lit is attached or another expansion block connected to the subsequent stage, or an error in a unit in the expansion block.

■ Solution

Clarify the situation in the following procedure.



◆ PROCEDURE

1. **Check if the power supplies to all the expansion blocks registered in the I/O map are ON.**
2. **Check the wiring conditions of expansion cables and power supplies.**
3. **Check if the end unit is connected at the end of the expansion block.**
4. **Check if an error occurs in a unit in the expansion block.**

If a unit error occurs, refer to the manual of each unit and find the cause of the error.
5. **Clear the self-diagnostic error of the CPU unit.**
6. **Turn on the power to the expansion units first, and then turn on the power to the CPU unit.**



◆ KEY POINTS

- The expansion unit startup wait time can be set in the I/O map dialog box. The settable range is 5 to 1800 seconds (30 minutes). The default is 5 seconds.
- A self-diagnostic error (Error code 6: Expansion unit power supply synchronization error) will occur if the power to the expansion block does not turn on after the startup wait time passed since the power to the CPU unit has turned on. Check the power supply sequence.
- When more than one expansion block is used, the ERROR LED, on the expansion slave units in the expansion block of the next stage connected to the expansion block to which the power supply is off, does not turn on.

7

Maintenance and Inspection

7.1 Handling of Backup Battery

7.1.1 Functions of Backup Battery

When the calendar timer function is to be used, attach the separately sold backup battery.

■ **Area backed up by the backup battery**

Calendar timer data

■ **Types of Backup Battery (separately sold)**

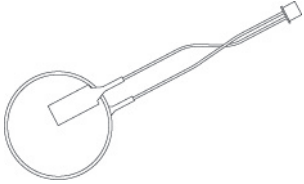
Appearance	Product name	Description	Product no.
	Backup battery	With a connector	AFPX-BATT



◆ **KEY POINTS**

- **Calendar timer values can continue operation for about one week by the built-in capacitor, even if no battery is used.**
- **In order to charge the built-in capacitor, supply power to the CPU unit for at least 30 minutes.**

7.1.2 Replacement of Backup Battery

FP7 CPU unit's backup battery can be replaced while power is on. Replace the backup battery in the following procedure.

■ Procedure

1. Open the SD memory card cover on the surface of the CPU unit.

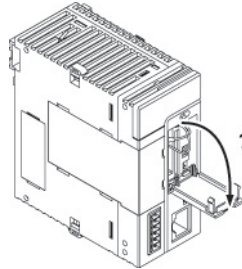

2. Remove the battery connector.

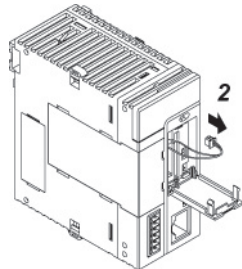

3. While extending the lever to outside, take out the backup battery from the battery holder.

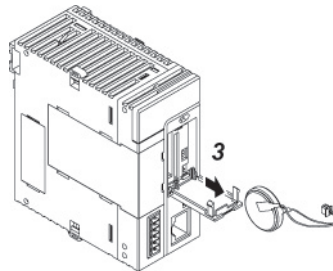

4. While extending the lever to outside, attach a new backup battery to the battery holder.
5. Connect to a power supply connector
6. Close the card cover.



◆ KEY POINTS

- For the FP7 CPU unit, the battery can be replaced while power is on. If the battery is to be replaced while power is off, undertake replacement within 10 minutes from powering off, after supplying power for at least 5 minutes, in order to charge the built-in capacitor. If the built-in capacitor has not been sufficiently charged, calendar timer data may become indefinite. **Make sure that the battery connector cable is not pinched by the card cover.**

7.1.3 Lifetime and Replacement Interval of Backup Battery

■ Lifetime of backup battery

Lifetime of backup battery	Suggested replacement interval
3.3 years or more	5 years

(Note 1) The lifetime indicated above is the value when no power at all is supplied.

(Note 2) Note that the lifetime in actual use may be shorter than the indicated value depending on the use conditions.

(Note 3) Backup battery is consumed for the backup battery detection circuit, even while power is being supplied.

Lifetime while power is being supplied is approx. two times longer than the value when no power is supplied.

■ Detection of errors and replacement interval of backup battery

- When voltage of the backup battery declines, the system relays (SR24 and SR25) are turned on. As necessary, create a program for reporting the error to outside.
- If the system register's "Report Battery Error" setting is turned valid, the CPU ERROR LED on the CPU unit flashes.
- Promptly replace the battery, though data are retained for about one week from the detection of a backup battery error, even if no power at all is supplied.



◆ NOTES

- **The retained memory data may become indefinite after one week has passed with no power supplied, from the time when the system relays (SR24 and SR25) turned on or when the ERROR LED on the CPU unit flashed.**
- **The system relays (SR24 and SR25) turn on when a backup battery error is detected, regardless of settings in the CPU's configuration.**
- **Regardless of time passed from detection of a backup battery error, supply power to the CPU unit for at least 5 minutes before replacing the backup battery.**

7.2 Inspection

In order to use the unit in the optimal conditions, ensure routine/periodic inspection.

■ Inspection items

Inspection Items	Description	Criteria	Related Pages
Power Supply Unit	Check POWER LED on power supply unit	Normal if on	p.2-5
	Body of the Power Supply Unit	Periodic replacement	p.2-5
Display on the CPU unit	Check of the RUN MODE INDICATION LED Check of the CPU ERROR LED Check of the ALARM LED	On in the RUN mode Normally off Normally off	p.2-2
Installation	Installation to the DIN rail (Is there any looseness?) Is there any looseness of the unit?	The unit should be securely installed.	p.4-2 to p.4-5
Connection status	Loose terminal screw Proximity to a solderless terminal Loose connector Connection of expansion cables	There should be no looseness. The screws should be evenly fastened. Locking should be on. There should be no looseness in the connector part.	p.4-8 to p.4-11
Voltage of the power supply unit	Voltage between terminals	100 to 240V AC	p.4-8, p.8-25 to p.8-26
Power supply voltage of the CPU unit/Expansion slave unit	Voltage supplied to the power supply connector	24V DC	p.1-11, p.8-2
Ambient environment	Ambient temperature / in-board temperature Ambient humidity / in-board humidity Ambient air	0 to +55°C 10 to 95%RH Free from corrosive gases and excessive dust	p.4-2
Backup battery	Backup battery for the CPU unit	Periodic replacement	p.7-2 to p.7-4

8

Specifications

8.1 CPU Unit Specifications

8.1.1 General Specifications

Items	Description	
Rated voltage	24V DC	
Operating voltage range	20.4 to 28.8V DC (Note 1)	
Momentary power off time	When the CPU unit only (DC) is used 4 ms (20.4 V is used) , 7 ms (24 V is used) , 10 ms (28.8 V is used) (Note 2)	
Operating ambient temperature	0 to +55°C	
Storage ambient temperature	-40 to +70°C	
Operating ambient humidity	10 to 95%RH (at 25°C, no-condensing)	
Storage ambient humidity	10 to 95%RH (at 25°C, no-condensing)	
Breakdown voltage (Note 3)	All of the COM port, USB and LAN port - All of the power supply terminals and functional earths	500V AC, 1 minute
Insulation resistance (Note 4)	All of the COM port, USB and LAN port - All of the power supply terminals and functional earths	100 MΩ or larger
Vibration resistance	Based on JIS B 3502 and IEC 61131-2: 5 to 8.4 Hz, half amplitude 3.5 mm 8.4 to 150 Hz, constant acceleration 9.8 m/s ² X, Y and Z axes, 10 minutes, 10 sweeps (1 octave/mm)	
Shock resistance	Based on JIS B 3502 and IEC 61131-2 147 m/s ² , X, Y and Z axes, 3 times	
Noise resistance	1,000 V[P-P] with pulse widths 50 ns and 1 μs (using a noise simulator) (power supply terminals)	
Environment	Free from corrosive gases and excessive dust.	
EU Directive applicable standard	EMC Directive: EN 61131-2, Low-Voltage Directive: EN 61131-2	
Overvoltage category	Category II or lower	
Pollution degree	Pollution degree 2 or lower	

(Note 1) When a programmable display GT series is connected to the GT power supply terminal of the CPU unit, use it within the range of 21.6 to 26.4 V DC.

(Note 2) 10 ms when an AC power supply unit (AFP7PSA1/AFP7PAS2) is used

(Note 3) Cutoff current: 50 mA

(Note 4) With 500 V DC megohmmeter

■ Weight

Product name		Model number	Weight	
Power Supply Unit	100 to 240V AC, 24W	AFP7PSA1	Approx. 240g	
	100 to 240V AC, 3W	AFP7PSA2	Approx. 290g	
CPU Unit		AFP7CPS*	Approx. 220g	
Add-on Cassette (Communication Cassette)		AFP7CCS1, AFP7CCS2, AFP7CCM1, AFP7CCM2, AFP7CCS1M1	Approx. 25g	
		AFP7CCET1	Approx. 20g	
Add-on Cassette (Function Cassette)		AFP7FCA21, AFP7FCAD2, AFP7FCTC2	Approx. 25g	
Input Unit	DC input	16-point terminal block	AFP7X16DW	Approx. 125g
		32-point MIL connector	AFP7X32D2	Approx. 95g
		64-point MIL connector	AFP7X64D2	Approx. 110g
Output Unit	Relay output	16-point terminal block	AFP7Y16R	Approx. 180g
	Transistor output	16-point terminal block	AFP7Y16T, AFP7Y16P	Approx. 125g
		32-point MIL connector	AFP7Y32T, AFP7Y32P	Approx. 95g
		64-point MIL connector	AFP7Y64T, AFP7Y64P	Approx. 115g
I/O Mixed Unit		Input 32-point / Output 32-point MIL connector	AFP7XY64D2T, AFP7XY64D2P	Approx. 115g
Analog Input Unit	4ch		AFP7AD4H	Approx. 130g
	8ch		AFP7AD8	Approx. 130g
Analog Output Unit		4ch	AFP7DA4H	Approx. 130g
Thermocouple multi-analog input unit			AFP7TC8	Approx. 145g
RTD input unit			AFP7RTD8	Approx. 145g
High-speed Counter Unit			AFP7HSC2T, AFP7HSC4T	Approx. 130g
Pulse Output Unit	2-axis		AFP7PG02T, AFP7PG02L	Approx. 130g
	4-axis		AFP7PG04T, AFP7PG04L	Approx. 150g
Positioning Unit	2-axis		AFP7PP02T, AFP7PP02L	Approx. 145g
	4-axis		AFP7PP04T, AFP7PP04L	Approx. 145g
Serial Communication Unit			AFP7NSC	Approx. 110g
PHLS Master Unit			AFP7RMTM	Approx. 110g
PHLS Slave Unit	8-point terminal block		AFPRP1X08D2	Approx. 140g
	16-point terminal block		AFPRP1X16D2, AFPRP1Y16T AFPRP1XY16D2T	Approx. 210g
	e-Con,		AFPRP2X08D2E	Approx. 75g
	Small terminal block		AFPRP2X16D2, AFPRP2Y16T AFPRP2XY16D2T, AFPRP2Y04R	Approx. 75g
Expansion master unit			AFP7EXPM	Approx. 120g
Expansion slave unit (including an end unit)			AFP7EXPS	Approx. 200g

8.1.2 Performance Specifications

Items		Description	
Program method		Relay symbol method	
Control method		Cyclic operation method	
Controllable I/O points	Basic configuration	Max. 1,024 points (64 points x 16 slots)	
	When the PHLS remote I/O system is used	Max. 16,128 points (1,008 points x 16 slots)	
Program memory	Built-in memory	Execution project saving memory (RAM and ROM1) : Non-volatile memory Backup project saving memory (ROM2) : Non-volatile memory	
	Memory capacity	(Note 1)	
	Max. program blocks	(Note 1)	
Comment memory	Memory capacity	3 M bytes (all comments including I/O comments, note comments, and block comments)	
Operation speed		Basic instructions: Min. 11 ns / step	
Basic instructions		Approx. 100 types	
High-level instructions		Approx. 206 types	
Operation memory	1-bit device	External inputs (X)	8,192 points (X0 to X511F) (Note 2) (Note 3)
		External outputs (Y)	8,192 points (Y0 to Y511F) (Note 2) (Note 3)
		Internal relays (R)	32,768 points (R0 to R2047F) (Note 3)
		Link relays (L)	16,384 points (L0 to L1023F) (Note 3)
		Timers (T)	4,096 points (T0 to T4095) (Note 3) Can count up to (Unit: 10us,1ms,10ms,100ms,1s) × 4,294,967,295
		Counters (C)	1,024 points (C0 to C1023) (Note3) Can count up to 1 to 4,294,967,295
		System relays (R)	1120 points (approx. 70 words)
		Pulse relays (P)	4,096 points (P0 to P255F) (Note 3)
		Error alarm relays (E)	4,096 points (E0 to E4095) (Note 3)
		Direct input (IN)	Allocate input numbers to each slot (IN0 to IN62F) (Note 3) (Note 4)
	Direct output (OT)	Allocate output numbers to each slot (OT0 to OT62F) (Note 3) (Note 4)	
	16-bit device	Data register (DT)	(Note 1) (Note 3)
		Link data register (LD)	16,384 words (LD0 to LD16383) (Note 3)
		Unit memory (UM)	Max. 512 K words per unit (Note 4)
		System data register (SD)	110 words
	32-bit device	Index register	15 double words (I0 to IE) (with a switching function) (Note 3)
		Timer set value register (TS)	4,096 double words (TS0 to TS4095) (Note 3)
		Timer elapsed value register (TE)	4,096 double words (TE0 to TE4095) (Note 3)
		Counter set value register (CS)	1,024 double words (CS0 to CS1023) (Note 3)
		Timer/counter elapsed value register (CE)	1,024 double words (CE0 to CE1023) (Note 3)

Items	Description
Master control relay (MCR)	No limits (no numbers)
Labels (JMP, LOOP)	Max. 65,535 points per PB
Differential points (DF, DFI)	Depending on the program capacity
No. of step ladders	No restriction
No. of subroutines	Max. 65,535 points per PB
Interrupt program	Fixed cycle execution type PB: 1 PB/per project Execution interval unit: 0.1 ms or 1 ms
	Interrupt from High-speed counter unit Max. 8 points per unit, Max. 8 units per project
Constant scan	0.5 to 125 ms
Memory backup for power failure	Built-in non-volatile memory backs up the project (program, comments and configuration data) and operation memory. (Excluding calendar timer)
Calendar timer	Yes (a separately sold backup battery is required) (Note 5) (Note 6)
Self-diagnosis function	Watchdog timer, program syntax check
Rewriting during RUN function	Yes (rewriting on a PB basis, no limit to the number of rewriting steps)
Security function	Password function, no-read settings, encryption can be set for the program, comments and configuration data

(Note 1) The program capacity, data register capacity and maximum number of program blocks (PBs) vary according to the type of CPU and memory configuration settings. They are set from the configuration menu of tool software FPWIN GR7. The default values are pattern 3 for CPS4 and pattern 1 for CPS3.

Unit type	Memory type	Memory select pattern				
		1	2	3	4	5
CPS4*	Program capacity (step)	234,000	221,500	196,000	144,500	51,500
	Data register capacity (word)	65,536	131,072	262,144	524,288	999,424
	Maximum number of PBs	468	443	392	289	103
CPS3*	Program capacity (step)	121,500	96,000	64,000	32,000	
	Data register capacity (word)	131,072	262,144	425,984	589,824	
	Maximum number of PBs	243	192	128	64	

(Note 2) Figures in the table indicate the number of devices that can be used in the program. The actual inputs and outputs that can be used vary by configuration.

(Note 3) Operation devices are categorized into "hold type", which memorizes the status immediately before power failure or switch to the PROG. mode, and "non-hold type", which resets such status. Internal relays, data registers, link relays and link registers can be set as non-hold type or hold type by the tool software. Counters and error alarm relays are hold type. Other operation memories are non-hold type. However, data registers that can be used as hold type are a maximum of 262,144 words.

(Note 4) Direct inputs (IN), direct outputs (OT), and unit memories (UM) are used by specifying unit slot numbers and memory addresses to be controlled by instructions.

(Note 5) Battery lifetime: 3.3 years or more, suggested replacement interval: 5 years.

After power is supplied to the CPU unit for 30 minutes or longer, data can be retained for approx.one week by the internal capacitor even without a battery.

(Note 6) Precision of the calendar timer (real-time clock): Difference less than 95 seconds per month (0°C), less than 15 seconds per month (+25°C), less than 130 seconds per month (+55°C).

When the unit is connected to ET-LAN, the time is synchronized by the SNTP function.

Specifications

8.1.3 CPU Unit Communication Specifications

■ USB port (for tool software)

Items	Description
Standard	USB2.0 FULL SPEED
Communication function	MEWTOCOL-COM (slave), MEWTOCOL7-COM (slave)

■ COM0 port

Items	Description
Interface	RS-232C
Transmission distance	15 m
Baud rate	300, 600, 1,200, 2,400, 4,800, 9,600, 19,200, 38,400, 57,600, 115,200 bit/s
Communication method	Half-duplex transmission
Synchronous method	Start stop synchronous system
Communication format	Data length: 7 bit / 8 bits Parity: Yes / No (Odd / Even) Start code: Without STX / With STX End code: CR / CR + LF / None / ETX Stop bit: 1 bit / 2 bits
Data transmission order	Transmits from bit 0 character by character.
Communication function	MEWTOCOL-COM (master/slave), MEWTOCOL7-COM (slave) MODBUS RTU (master/slave) general-purpose communication modem initialization

(Note 1) Baud rate, transmission format, and applications of communication should be set using the tool software.

(Note 2) When communication is performed at a baud rate of 38,400 bps or higher, use the cable not longer than 3 m.

For wiring the RS232C, a shielded wire must be used to increase noise suppression.

(Note 3) When connecting a commercially available device, please confirm operation using the actual device.

■ LAN port (CPS4E / CPS41E/ CPS3E / CPS31E)

Items	Description
Interface	100BASE-TX / 10BASE-T
Baud rate	100 Mbps, 10 Mbps auto-negotiation (Note 1)
Transmission system	Baseband
Max. segment length	100 m (Note 2)
Communication cable	UTP (Category 5)
Max. distance between nodes	100BASE-TX: 2 segments
	10BASE-T: 5 segments
No. of nodes	254 unit
Number of simultaneous connections	User connections: 16
	System connections: 4
Communication protocol	TCP/IP, UDP/IP
DNS	Supports name server
DHCP	Automatic getting of IP address
FTP server	File transmission, server function, No. of users: 3
SNTP	Time synch function
Communication function	MEWTOCOL-DAT (master/slave), MEWTOCOL-COM (master/slave), MEWTOCOL7-COM (slave) MODBUS-TCP (master/slave) general-purpose communication (16 kB per connection)

(Note 1) Switching between different speeds is done automatically by auto negotiation function.

(Note 2) The standards cite 100 m as the maximum, but noise resistance measures such as attaching a ferrite core may be necessary in some cases, depending on the usage environment. Also, it is recommended to position a hub near the control board, and limit the length within 10 m

(Note 3) System connection is used when connecting tool software via LAN.

8.1.4 Operation Memory Area

Name		Usable devices and ranges	Functions
1-bit device	External input X	8,192 points (X0 to X511F) (Note 1)	Turns on or off based on external input.
	External output Y	8,192 points (Y0 to Y511F) (Note 1)	Externally outputs on or off state.
	Internal relay R	32,768 points (R0 to R2047F) (Note 2)	Relay which turns on or off only within program.
	Link relay L	16,384 points (L0 to L1023F) (Note 2)	This relay is a shared relay used for PLC link.
	Timer T	4,096 points (T0 to T4095) (Note 2)	This goes on when the timer reaches the specified time.
	Counter C	1,024 points (C0 to C1023) (Note 2)	This goes on when the timer increments.
	System relay SR	Approx. 1120 points (approx. 70 words)	Relay which turns on or off based on specific conditions and is used as a flag.
	Pulse relay P	4,096 points (P0 to P255F)	This relay only turns on during one scan at the start of the execution condition.
	Error alarm relay E	4,096 points (E0 to E4095)	This relay ensures that error conditions that are freely allocated by the user are memorized in the memory.
	Direct input IN	Can allocate input numbers to each slot (IN0 to IN62F) (Note 3)	This relay is for input/output processing during operation, without depending on usual I/O refresh.
	Direct output OT	Can allocate output numbers to each slot (OT0 to OT62F) (Note 3)	
16-bit device	External input ^(Note1) WX	WX0 to WX511 (Note 1)	Code for specifying 16 external input points as one word (16 bits) of data.
	External output ^(Note1) WY	WY0 to WY511 (Note 1)	Code for specifying 16 external output points as one word (16 bits) of data.
	Internal relay WR	WR0 to WR2047 (Note 2)	Code for specifying 16 internal relay points as one word (16 bits) of data.
	Link relay WL	WL0 to WL1023	Code for specifying 16 link relay points as one word (16 bits) of data.
	Data register DT	Max. DT 999424 words (DT0 – DT999423) (Note 2) (Note 4)	Data memory used in program. Data is handled in 16-bit units (one word).
	Link register LD	16,384 words (LD0 to LD16383) (Note 2)	This is a shared data memory which is used within the PLC link. Data is handled in 16-bit units (one word).
	Unit memory UM	Max. 512K words per unit (Note 3)	This device is for accessing the unit memory of intelligent units. Its size varies by unit, and is allocated by default.
	System data register SD	Approx. 110 words	Data memory for storing specific data. Various settings and error codes are stored.

Name		Usable devices and ranges	Functions	
32-bit device	Index register	I	15 double words (I0 to IE) (with a switching function)	Register can be used as an address of memory area and constants modifier.
	Timer set value area	TS	4,096 double words (TS0 to TS4095) (Note 2)	Data memory for storing timer target data. It corresponds to the timer number.
	Timer elapsed value area	TE	4,096 double words (TE0 to TE4095) (Note 2)	Data memory for storing timer elapsed value. It corresponds to the timer number.
	Counter set value area	CS	4,096 double words (CS0 to CS4095) (Note 2)	Data memory for storing counter set value. It corresponds to the counter number.
	Counter elapsed value area	CE	4,096 double words (CE0 to CE4095) (Note 2)	Data memory for storing the elapsed value during operation of a counter. It corresponds to the timer number.
Constant	Signed decimal constants	K	K-32768 to K32767	(for 16-bit operation)
			K-2147483648 to K2147483647	(for 32-bit operation)
	Unsigned decimal constants	U	U 0 to U65535	(for 16-bit operation)
			U 0 to U4294967295	(for 32-bit operation)
	Hexadecimal constants	H	H0 to HFFFF	(for 16-bit operation)
			H0 to HFFFFFFFF	(for 32-bit operation)
	Single precision floating point number (real number)	SF	SF-1.175494 × 10 ⁻³⁸ to SF-3.402823 × 10 ³⁸	
			SF-1.175494×10 ⁻³⁸ to SF-3.402823×10 ³⁸	
Double precision floating point number (real number)	DF	DF-2.2250738585072014 × 10 ⁻³⁰⁸ to DF-1.7976931348623158 × 10 ³⁰⁸		
		DF 2.2250738585072014 × 10 ⁻³⁰⁸ to DF 1.7976931348623158 × 10 ³⁰⁸		

(Note 1) Figures in the table indicate the number of devices that can be used in the program. The actual inputs and outputs that can be used vary by configuration.

(Note 2) Operation devices are categorized into "hold type", which memorizes the status immediately before power failure or switch to the PROG. mode, and "non-hold type", which resets such status. Non-hold area is cleared to zero when the unit is powered on or the mode is switched between PROG and RUN.

Types of operation devices	Hold or Non-hold
Internal relays (R), Data registers (DT), Link relays (L), Link registers (LD)	Can be set as non-hold type or hold type by the tool software. However, data registers that can be used as hold type are a maximum of 262,144 words.
Counters (C), Counter set values (CS), Counter elapsed values (CE), Error alarm relays (E)	Hold type
Inputs (X), Outputs (Y), Timers (T), Timer set values (TS), Timer elapsed values (TE), Pulse relays (P), Direct inputs (IN), Direct outputs (OT), Index registers (I), Unit memories (UM), System data registers (SD)	Non-hold type

(Note 3) Direct inputs (IN), direct outputs (OT), and unit memories (UM) are used by specifying unit slot numbers and memory addresses to be controlled by instructions.

(Note 4) The number of usable data registers (DT) varies according to the type of CPU and memory configuration settings.

Unit type	Memory type	Memory select pattern				
		1	2	3	4	5
CPS4*	Data register capacity (word)	65,536	131,072	262,144	524,288	999,424
CPS3*	Data register capacity (word)	131,072	262,144	425,985	589,824	



8.1.5 List of System Relays

WS0

Device number	Name	Description
SR0	Self-diagnostic error flag	Turns on when a self-diagnosis error occurs. Self-diagnosis error codes are saved in the system data register SD0.
SR1	Unit alarm occurrence	Turns on when a unit alarm is detected. The slot number of the unit where an alarm has occurred is saved in the system data register SD1.
SR2	Unit error occurrence	Turns on when a unit error is detected. The slot number of the unit where an error has occurred is saved in the system data register SD2.
SR3	Unit warning occurrence	Turns on when a unit warning is detected. The slot number of the unit where a warning has occurred is saved in the system data register SD3.
SR4	Unit verification error occurrence	Turns on when an I/O verification error is detected. The slot number of the unit where an I/O verification error has occurred is saved in the system data register SD4.
SR5	Unit installation error detection	Turns on when a unit installation error is detected. The slot number of the unit where an I/O verification error has occurred is saved in the system data register SD5.
SR6	(Not used)	
SR7	Operation error flag (hold type)	Turns on when an operation error occurs after the unit has started operating, and remains on while the unit operation continues. The PB number where an error has occurred is saved in the system data SD7, and the address is saved in system data registers SD8 to SD9. It indicates the first operation error that has occurred.
SR8	Operation error flag (latest type)	Turns on every time an operation error occurs. The PB number where an operation error has occurred is saved in the system data register SD10, and the address is saved in system data registers SD11 to SD12. Every time a new error occurs, the data are updated. It does not turn off even if the instruction is normally completed after the occurrence of the error(s). In order to check if any error has occurred in a specific instruction, either see address data saved in the SD, or clear error flags using ERR instruction immediately before the specific instruction, and check flags immediately after executing the instruction.
SR9	Carry flag (CY flag)	Used in shift instruction and rotate instruction with a carry flag. The flag can also be operated in carry set instruction and carry reset instruction. It is not set in overflow or underflow of operation results. Turns on when an error occurs during the execution of Ethernet communication instruction. The error code is stored in the system data register SD29.
SRA	> flag	Executes comparison instruction, and turns on if the result is larger.
SRB	= flag	Executes comparison instruction, and turns on if the result is equal. Executes operation instruction, and turns on if the result is '0'.
SRC	< flag	Executes comparison instruction, and turns on if the result is smaller.
SRD	Support timer instruction flag	Turns on after support timer instruction (SPTM) is executed and subsequently specified time has passed. Turns off when execution conditions go off.
SRE	All error alarms relay	Turns on when any of the error alarm relays E0 to E4095 turns on. Turns off once all of the error alarm relays go off.

SRF	Constant scan error flag	Turns on if scan time exceeds the setting during constant scan. It also turns on if '0' is set in FP7 configuration.
-----	--------------------------	--

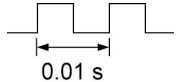
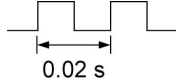
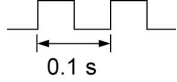
WS1

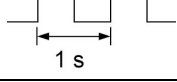
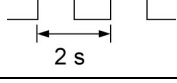
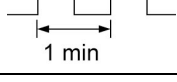
Device number	Name	Description
SR10	Normally-on relay	Is normally on.
SR11	Normally-off relay	Is normally off.
SR12	Scan relay	Turns on or off in each scan.
SR13	Initial pulse relay (ON)	Goes on for only the first scan after operation (RUN) has been started, and goes off for the second and subsequent scans.
SR14	Initial pulse relay (OFF)	Goes off for only the first scan after operation (RUN) has been started, and goes on for the second and subsequent scans.
SR15	Stepladder Initial pulse relay (ON)	Turns on in the first scan only, following startup of any single process, during stepladder control.
SR16	PB initial relay (ON)	Turns on at the start of execution of a program block. Turns off in the next scan.
SR17	PB initial relay (OFF)	Turns off at the start of execution of a program block. Turns on in the next scan.
SR18	0.01-second clock pulse relay	Clock pulse with a 0.01-second cycle 
SR19	0.02-second clock pulse relay	Clock pulse with a 0.02-second cycle 
SR1A	0.1-second clock pulse relay	Clock pulse with a 0.1-second cycle 
SR1B	0.2-second clock pulse relay	Clock pulse with a 0.2-second cycle 
SR1C	1-second clock pulse relay	Clock pulse with a 1-second cycle 
SR1D	2-second clock pulse relay	Clock pulse with a 2-second cycle 
SR1E	1-minute clock pulse relay	Clock pulse with a 1-minute cycle 
SR1F	Not used	

Specifications

WS2

Device number	Name	Description
SR20	CPU operation modes	ON: RUN mode OFF: PROG. mode
SR21	Operation program memory	ON: SD memory card OFF: ROM
SR22	RTC data error	Turns on if an error is detected in calendar timer data when the unit is powered on.
SR23	Power supply unit lifetime warning	Turns on when it is detected that a power supply unit is close to its lifetime.
SR24	RTC backup battery error flag (hold type)	Turns on when an RTC backup battery error is detected. The flag turns on if the battery is out, even if battery error alarm is disabled in the configuration menu. Once a battery error has been detected, this is held even after recovery has been made. The flag is turned off when power supply is cut off.
SR25	RTC backup battery error flag (current type)	Turns on when an RTC backup battery error is detected. Is off in the normal status. The flag turns on if the battery is out, even if battery error alarm is disabled in the configuration system register.
SR26	SNTP time updating failure	Turns on if acquisition of time data has failed during time synch via LAN port. Turns off in normal conditions.
SR27	SNTP time update completed	Turns off when time is being updated with SNTP, and turns on when the update is completed. (Note1)
SR28	(Not used)	
SR29	Forcing flag	Turns on while forced input/output operations are in progress.
SR2A	Interrupt enable	Turns on when interrupt is enabled.
SR2B	Interrupt error flag	Turns on when an interrupt error occurs.
SR2C	Interrupting flag	Turns on when an interrupt program is being executed. Only valid within a PB for execution at a specified interval or within an INT program.
SR2D	PB for execution at a specified interval in progress	Turns on when a PB (program block) for execution at a specified interval is being executed.
SR2E	(Not used)	
SR2F	Rewriting during RUN completed	Turns on in the first scan only following completion of rewriting during RUN.

(Note 1) Available from the CPU unit Ver.3.03 or later.

WS3

Device number	Name	Description
SR30	SD slot cover status flag	ON: Cover open OFF: Cover closed
SR31	SD memory card attachment flag	ON: With an SD memory card OFF: Without an SD memory card
SR32	SD memory card recognition completed flag	ON: Completed recognition of an SD memory card OFF: Other than the above
SR33	SD memory card recognition result flag	ON: Error OFF: Normal
SR34	SD memory card write protection flag	ON: Protected OFF: Not protected
SR35	SD memory card type	ON: SD OFF: SDHC
SR36	SD memory card file system	ON: FAT16 OFF: FAT32
SR37	Logging into FTP server	Turns on while logging in.
SR38	Logging trace execution	ON: Being executed OFF: Stops
SR39	Logging trace start	ON: Starts OFF: Stops
SR3A	SD card access instruction execution	This relay is used to check whether other SD card access instructions are executed or not. ON: Being executed OFF: Stops
SR3B	SD card access instruction completed	This relay is used to check the completion of SD card access instruction with the change of this flag (ON to OFF), and used to turn off the trigger of the instruction. ON: Completed OFF: Being executed
SR3C	SD card access instruction execution result	The execution result of SD card access instruction is stored. Error codes are stored in system data register SD30. ON: Error OFF: Normal
SR3D - SR3E	(Not used)	
SR3F	Powered off while accessing SD memory card (registration of records is required)	Turns on if the CPU unit is powered off while accessing an SD memory card.

Specifications

WS10 (Logging trace control relays: For LOG0)

Device number	Name	Description
SR100	Logging trace execution	Turns on when the logging trace is performed. Other relays in LOGn turns off while this relay turns on. Storing data in the buffer memory is executed while this relay turns on.
SR101	SD card logging execution	Turns on when writing files to a SD card becomes enabled after the logging trace execution relay turned on (buffer logging was enabled).
SR102	Logging trace completed	Turns on after the completion of file writing when stopping the logging trace is requested or it is automatically stopped.
SR103	Logging excessive speed relay	Turns on when the buffer logging speed exceeds the writing speed to a SD memory card in logging operations. Turns on when the number of data stored previously and the number of data stored this time increase. Turns on at the timing of buffer logging, and turns off at the timing of buffer logging or the end of scan.
SR104	Buffer overflow	Turns on when the buffer memory has been exhausted. At that time, new data cannot be stored. The value of the buffer overflow counter SD120 is incremented (+1). In that case, writing to SD card does not stop. Turns off at the end of scan when buffer vacancy occurs while writing to a SD memory card is performed. The buffer overflow counter SD120 is cleared to 0. After buffer vacancy occurred, data logging is executed at the timing of logging to the buffer.
SR105	Logging trace error	Turns on when an error is detected during the logging trace and stops the logging trace.
SR106	No SD card free space	Turns on when an error is detected during the logging trace and stops the logging trace.
SR107	Device and trigger setting error	Turns on when an error is detected in setting values during the startup operation. The error relay SR105 also turns on. At that time, the execution relay SR100 does not turn on as the logging trace function cannot be started.
SR108	Tracing stop trigger monitor	Monitors a registered trace stop trigger when executing tracing. Turns on when conditions are met.
SR109	Trace data acquisition complete	Turns on after logging data for a specified number of times after detecting the tracing stop trigger during the execution of trace.
SR10A - SR10F	(Not used)	

WS11 - WS25 (Logging trace control relays: For LOG1 - LOG15)

Device number	Name	Description
SR110 -SR119	Logging trace control relay For LOG1	For the details of each control relay, refer to the previous page.
SR120 -SR129	Logging trace control relay For LOG2	
SR130 -SR139	Logging trace control relay For LOG3	
SR140 -SR149	Logging trace control relay For LOG4	
SR150 -SR159	Logging trace control relay For LOG5	
SR160 -SR169	Logging trace control relay For LOG6	
SR170 -SR179	Logging trace control relay For LOG7	
SR180 -SR189	Logging trace control relay For LOG8	
SR190 -SR199	Logging trace control relay For LOG9	
SR200 -SR209	Logging trace control relay For LOG10	
SR210 -SR219	Logging trace control relay For LOG11	
SR220 -SR229	Logging trace control relay For LOG12	
SR230 -SR239	Logging trace control relay For LOG13	
SR240 -SR249	Logging trace control relay For LOG14	
SR250 -SR259	Logging trace control relay For LOG15	

Specifications

WS100 - WS149

Device number	Name	Description	
SR1000 to SR1499	Program block PB starting up relay	Can monitor program blocks that are being started up. SR1000 to SR1499 are allocated to 500 PBs.	
		Device number	PB number
		SR1000	PB 000
		SR1001	PB 001
		SR1002	PB 002
		-----	-----
		SR1009	PB 009
		SR1010	PB 010
		SR1011	PB 011
		-----	-----
		-----	-----
		SR1498	PB498
		SR1499	PB499

8.1.6 List of System Data Registers

SD0 – SD39

Device number	Name	Description	
SD0	Self-diagnostic error code	Stores the error code when a self-diagnosis error occurred.	
SD1	Alarm Occurrence Unit Slot No.	Saves the slot number of the unit where an alarm has occurred.	
SD2	Error Occurrence Unit Slot No.	Saves the slot number of the unit where an error has occurred.	
SD3	Warning Occurrence Unit Slot No.	Saves the slot number of the unit where a warning has occurred.	
SD4	Verification Error Occurrence Unit Slot No.	Saves the slot number of the unit where a verification error has occurred.	
SD5	Installation error detection slot No.	Saves the slot number of the unit where an installation error was detected.	
SD6	(Not used)		
SD7	Operation error occurrence PB number (hold type)	Saves the PB number where the first operation error occurred after the unit has started operating.	
SD8	Operation error occurrence address (hold type) (32-bit lower-level address)	Saves the address where the first operation error occurred after the unit has started operating. Perform monitoring using 32-bit data.	
SD9	Operation error occurrence address (hold type) (32-bit higher-level address)		
SD10	Operation error occurrence PB number (latest type)	Saves the PB number where an operation error occurred. Every time a new error occurs, the data are updated. The value '0' is recorded at the start of the scan.	
SD11	Operation error occurrence address (latest type) (32-bit lower-level address)	Saves the address where an operation error occurred. Every time a new error occurs, the data are updated. The value '0' is recorded at the start of the scan. Perform monitoring using 32-bit data.	
SD12	Operation error occurrence address (latest type) (32-bit higher-level address)		
SD13 to SD18	(Not used)		
SD19	RING counter 2.5 ms	The saved value is increased by one every time the respective time unit has passed. (H0 to HFFFF) Current values of SD19 to SD21 can only be read when SD19 to SD21 are directly specified and read by MV instruction. The scan start value is read by other instructions.	
SD20	RING counter 10 μ s		
SD21	RING counter 100 μ s		
SD22	Scan time (current value)	Saves the current value.	[Saved value (decimal)] x 10 μ s scan time indication: Indicates operation cycle time in the RUN mode only. Max. and Min. values are cleared at switching between the RUN mode and the PROG. mode.
SD23	Scan time (minimum value)	Stores the minimum value.	
SD24	Scan time (maximum value)	Saves the maximum value.	
SD25 to SD26	(Not used)		
SD27	Interval for PB for execution at a specified interval	Saves interval for PB for execution at a specified interval.	
SD28	(Not used)		
SD29	Ethernet communication error code	Saves the error code when the Ethernet communication instruction is executed.	
SD30	SD card access instruction execution result	Error codes while the SD card access instruction is executed are stored.	
SD31 to SD39	(Not used)		

(Note 1): SD0 to SD5 are available only when the corresponding system relays SR0 to SR5 are on.

Specifications

SD50 - SD85

Device number	Name	Description																																						
SD50	Calendar timer (year)	Saves year, month, day, hour, minute, second and day-of-the-week data of the calendar timer as 16-bit binary data. The built-in calendar timer will operate correctly through the year 2099 and support leap years. The calendar timer can be set (time synch) by writing desired values using the programming tool or a program based on calendar setting instruction (TIMEWT).																																						
SD51	Calendar timer (month)																																							
SD52	Calendar timer (day)																																							
SD53	Calendar timer (hour)																																							
SD54	Calendar timer (minute)																																							
SD55	Calendar timer (second)																																							
SD56	Calendar timer (day-of-the-week)																																							
SD60	Total ON number of error alarm relays	Saves the total number of error alarm relays that are on. (Max. 4096 relays) By specifying SD60 in RST instruction, all data in the error alarm buffer can be cleared.																																						
SD61	No.1 error alarm relay that turned on	Saves the number of the error alarm relay that turned on in the first place (No.1). By specifying SD61 in RST instruction, all data in the error alarm buffer can be cleared.																																						
SD62 to SD79	No.2 to No.19 error alarm relays that turned on	Saves the numbers of the error alarm relays that turned on. By specifying the device number in RST instruction, all data of the relevant relay(s) in the error alarm buffer can be cleared. Device numbers of system data registers SDs and error alarm relays correspond as follows. <table border="1" style="margin-left: auto; margin-right: auto;"> <thead> <tr> <th>Device number</th> <th>Error alarm relay</th> </tr> </thead> <tbody> <tr><td>SD62</td><td>No.2</td></tr> <tr><td>SD63</td><td>No.3</td></tr> <tr><td>SD64</td><td>No.4</td></tr> <tr><td>SD65</td><td>No.5</td></tr> <tr><td>SD66</td><td>No.6</td></tr> <tr><td>SD67</td><td>No.7</td></tr> <tr><td>SD68</td><td>No.8</td></tr> <tr><td>SD69</td><td>No.9</td></tr> <tr><td>SD70</td><td>No.10</td></tr> <tr><td>SD71</td><td>No.11</td></tr> <tr><td>SD72</td><td>No.12</td></tr> <tr><td>SD73</td><td>No.13</td></tr> <tr><td>SD74</td><td>No.14</td></tr> <tr><td>SD75</td><td>No.15</td></tr> <tr><td>SD76</td><td>No.16</td></tr> <tr><td>SD77</td><td>No.17</td></tr> <tr><td>SD78</td><td>No.18</td></tr> <tr><td>SD79</td><td>No.19</td></tr> </tbody> </table>	Device number	Error alarm relay	SD62	No.2	SD63	No.3	SD64	No.4	SD65	No.5	SD66	No.6	SD67	No.7	SD68	No.8	SD69	No.9	SD70	No.10	SD71	No.11	SD72	No.12	SD73	No.13	SD74	No.14	SD75	No.15	SD76	No.16	SD77	No.17	SD78	No.18	SD79	No.19
Device number	Error alarm relay																																							
SD62	No.2																																							
SD63	No.3																																							
SD64	No.4																																							
SD65	No.5																																							
SD66	No.6																																							
SD67	No.7																																							
SD68	No.8																																							
SD69	No.9																																							
SD70	No.10																																							
SD71	No.11																																							
SD72	No.12																																							
SD73	No.13																																							
SD74	No.14																																							
SD75	No.15																																							
SD76	No.16																																							
SD77	No.17																																							
SD78	No.18																																							
SD79	No.19																																							
SD80	For error alarm relay	Calendar timer (year)	Saves time when the error alarm relay saved in SD61 turned on.																																					
SD81		Calendar timer (month)																																						
SD82		Calendar timer (day)																																						
SD83		Calendar timer (hour)																																						
SD84		Calendar timer (minute)																																						
SD85		Calendar timer (second)																																						

SD100 - SD115 and SD120 - SD125 (For logging trace control)

Device number	Name	Description
SD100	Buffer free space for LOG0	Saves free space of buffer memory during logging. Unit: kB
SD101	Buffer free space for LOG1	
SD102	Buffer free space for LOG2	
SD103	Buffer free space for LOG3	
SD104	Buffer free space for LOG4	
SD105	Buffer free space for LOG5	
SD106	Buffer free space for LOG6	
SD107	Buffer free space for LOG7	
SD108	Buffer free space for LOG8	
SD109	Buffer free space for LOG9	
SD110	Buffer free space for LOG10	
SD111	Buffer free space for LOG11	
SD112	Buffer free space for LOG12	
SD113	Buffer free space for LOG13	
SD114	Buffer free space for LOG14	
SD115	Buffer free space for LOG15	
SD120	Buffer overflow counter for LOG0	Saves the number of times buffer overflow flags (e.g. SR104 for LOG0) turn on. For checking the number of times logging data is lost during the buffer overflow, register the buffer overflow counter as logging data.
SD121	Buffer overflow counter for LOG1	
SD122	Buffer overflow counter for LOG2	
SD123	Buffer overflow counter for LOG3	
SD124	Buffer overflow counter for LOG4	
SD125	Buffer overflow counter for LOG5	
SD126	Buffer overflow counter for LOG6	
SD127	Buffer overflow counter for LOG7	
SD128	Buffer overflow counter for LOG8	
SD129	Buffer overflow counter for LOG9	
SD130	Buffer overflow counter for LOG10	
SD131	Buffer overflow counter for LOG11	
SD132	Buffer overflow counter for LOG12	
SD133	Buffer overflow counter for LOG13	
SD134	Buffer overflow counter for LOG14	
SD135	Buffer overflow counter for LOG15	

8.1.7 Error Codes Table

Error codes 1 to 6

Code	Name	Operation	Error contents and steps to take
1	CPU hardware error 1	Stop	There may be a hardware problem. Please contact your dealer.
2	CPU hardware error 2	Stop	
3	I/O bus power supply error (including "no end cover")	Stop	Error in the I/O bus part is probable, such that the end unit has not been attached. Double-check the attachment status of units. This error also occurs when an expansion cable is removed during operation.
4	Unit attachment limit exceeded	Stop	is probable that the unit attachment limit has been exceeded. Double-check the configuration.
5	Project data error	Stop	Turns on when there is an error in project data.
6	Expansion unit power supply synchronization error	Stop	Turns on when there is an error in the expansion block side such that the power to the expansion unit is not on or the expansion cable is not connected correctly when the power turns on. The wait time until the power turns on can be set in the I/O map configuration dialog box.

Error codes 20 to 27

20	Syntax error	Stop Auto clear	A program with a syntax error has been written. Switch to the PROG. mode and correct the error.
21	Duplicated use	Stop Auto clear	<p>The same relay is used multiple times in OT instruction, etc. Switch to the PROG. mode and correct the error. Or, set the duplicated output to "enable" in the CPU configuration.</p> <p>Applicable devices and instructions are as follows.</p> <ul style="list-style-type: none"> • Operation device (X, Y, R, L), timer/counter instruction, SSTP instruction
22	Not paired	Stop Auto clear	<p>For instructions which must be used in a pair, one instruction is either missing or in an incorrect position. Switch to the PROG. mode and enter the two instructions which must be used in a pair in the correct positions.</p> <p>Applicable instructions and cases are as follows.</p> <ul style="list-style-type: none"> • MC and MCE are not paired. • LBLs corresponding to LOOP and JP are not located in the same area (normal program area / same sub-routine area / same interrupt program area). • There are no sub-routines corresponding to CALL and FCALL. • There is no STPE corresponding to SSTP.
24	Program area error	Stop Auto clear	<p>An instruction that can only be executed in a specified area is written in another location. Switch to the PROG. mode and correct the error.</p> <p>Applicable instructions and cases are as follows.</p> <ul style="list-style-type: none"> • LBL, LOOP, JP, MC and MCE are in the stepladder area. • MC is nested in more than 16 layers. • CNDE is outside the normal program area. • EDPB is outside the blank area. • ED is inside the sub-routine area or the interrupt area. • SBL is outside the blank area or the sub-routine area. • An interrupt program is outside the blank area or the interrupt program area. • RET is outside the sub-routine area. • IRET is outside the interrupt program area. • STPE is outside the stepladder area.
25	High-level instruction execution combination error	Stop Auto clear	In the program, high-level instructions, which execute in every scan and at the leading edge of the trigger, are programmed to be triggered by one contact. Correct the program so that the high-level instructions executed in every scan and only at the leading edge are triggered separately.
27	Compile memory full error	Stop Auto clear	The program is too large to compile in the program memory. Switch to the PROG. mode and reduce the total number of steps for the program.

(Note) For errors where "Auto clear" is indicated in the 'Operation' column, error clearance is executed when power supply is cut off, or when the unit is set to the RUN mode again after the status has been corrected.

Specifications

Error codes 40 to 55

Code	Name	Operation	Error contents and steps to take
40	Copy failure Cover open	Stop Auto clear	The card cover is open and the copy process cannot be executed. Close the cover.
41	Copy failure No SD card	Stop Auto clear	Copying cannot be executed because there is no SD memory card. Insert an SD memory card.
42	Copy failure SD card reading error (FAT / file error)	Stop Auto clear	Copying cannot be executed because the SD memory card is damaged. Insert a normal SD memory card.
43	Copy failure No file	Stop Auto clear	Copying cannot be executed because there is no file in the SD memory card. Check if a project file is saved in the card.
44	Copy failure password inconsistency (limited distribution function)	Stop Auto clear	Copying cannot be executed because the password for the project file saved in the SD memory card is not consistent with the password for the execution project saved in the built-in ROM. Check the password settings.
45	Copy failure Invalid project data	Stop Auto clear	Copying cannot be executed because an error has been identified in project data saved in the SD memory card. Check the project data.
50	SD operation impossible Cover open	Stop Auto clear	SD memory card operation cannot be executed because the card cover is open. Close the cover.
51	SD operation impossible No SD card	Stop Auto clear	SD memory card operation cannot be executed because there is no SD memory card. Insert an SD memory card.
52	SD operation impossible SD card reading error (FAT / file error)	Stop Auto clear	SD memory card operation cannot be executed because the SD memory card is damaged. Insert a normal SD memory card.
53	SD operation impossible No file	Stop Auto clear	SD memory card operation cannot be executed because there is no file in the SD memory card. Check if a project file is saved in the card.
54	SD operation impossible password inconsistency (limited distribution function)	Stop Auto clear	SD memory card operation cannot be executed because the password for the project file saved in the SD memory card is not consistent with the password for the execution project saved in the built-in ROM. Check the password settings.
55	SD operation impossible Invalid project data	Stop Auto clear	SD memory card operation cannot be executed because an error has been identified in project data saved in the SD memory card. Check the project data.
60	Duplicated or excessive collected I/O maps	Stop Auto clear	There is an error with I/O maps that have been collected in the CPU unit. Verify the registered data.
61	Duplicated or excessive registered I/O maps	Stop Auto clear	There is an error with I/O maps that have been registered in the CPU unit. Verify the registered data.
62	Interrupt error 1	Stop Auto clear	There may be a hardware problem. Please contact your dealer.
63	Interrupt error 2	Stop Auto clear	The interrupt program definition by INTPG instruction may be disappeared by rewriting during RUN. Check the program.

(Note) For errors where "Auto clear" is indicated in the 'Operation' column, error clearance is executed when power supply is cut off, or when the the same operation is executed again after the status has been corrected.

Error codes 80 to 106

Code	Name	Operation	Error contents and steps to take
80	Unit alarm occurrence	Select (Default stop)	An alarm has occurred in an attached unit. Check the status of the unit in the slot number saved in the system data register SD1.
81	Unit error occurrence	Select (Default stop)	An error has occurred in an attached unit. Check the status of the unit in the slot number saved in the system data register SD2. Verify the configuration settings.
82	Unit verification error detection	Select (Default stop)	Unit wiring condition has changed compared to that at the time of power-up. Check the status of the unit in the slot number saved in the system data register SD4.
83	Registered unit number inconsistency	Select (Default stop)	The number of units differs from that registered in the I/O map. Check the I/O map and the attachment status.
84	Unit initial completed Waiting timeout	Select (Default stop)	An error has occurred during the unit initial operation. Check the unit status.
85	Unit configuration data inconsistency with applicable unit	Select (Default stop)	The unit's configuration data is not consistent with the applicable unit. Check the I/O map and the configuration data.
86	Operation error	Select (Default stop)	An operation error has occurred. Reasons for an operation error vary by instruction. Refer to the Instruction Manual, etc. and correct the appropriate reasons. PB and address where an operation error has occurred are saved in the system data registers SD7 to SD12.
100	Bus current error	Select (Default continue)	A bus error is probable. Please contact your dealer.
104	Service power supply current error	Select (Default continue)	An error has been detected in the GT power supply terminal part. Check if it is correctly connected.
105	CPU temperature error 1	Select (Default continue)	A temperature rise has been detected in hardware. In general, select "Continue".
106	CPU temperature error 2	Select (Default continue)	

(Note 1) For errors where "Select" is indicated in the 'Operation' column, either "Stop" or "Continue" can be selected in the configuration menu.

Specifications

Error codes 120 to 127, 1000 to 2999

Code	Name	Operation	Error contents and steps to take
120	RTC data error	Continue	An error has been detected in clock data of the calendar timer.
121	Power supply unit lifetime warning	Continue	It is alarmed that the power supply unit is close to its lifetime. Replace the power supply unit.
122	Battery voltage decline	Continue	Voltage of the optional battery has declined. Replace the battery. If no battery is used, disable battery error alarm in the CPU configuration.
123	Gold capacitor voltage decline	Continue	It is alarmed that voltage of the built-in gold capacitor of the CPU unit has declined. Charge the CPU unit.
124	SNTP time acquisition failure	Continue	Acquisition of time data has failed during time synch via LAN port.
125	Logging settings mismatch	Continue	An error has been detected in logging data settings.
126	Logging data error	Continue	An error has been detected in logging data.
127	Comment data error	Continue	An error has been detected in comment data.
1000 to 1999	Error by ERR instruction	Stop	An error as specified by ERR instruction in the user program has occurred. Handle the error in accordance with the specified detection conditions.
2000 to 2999	Error by ERR instruction	Continue	

(Note 1) If an RTC data error is detected, the date is set to "April 1, 2012".

8.2 Power Supply Unit Specifications

8.2.1 General Specifications

Items	Description	
Operating ambient temperature	0 to +55°C	
Operating ambient humidity	10 to 95%RH (at 25°C, no-condensing)	
Storage ambient temperature	-40 to +70°C	
Storage ambient humidity	10 to 95%RH (at 25°C, no-condensing)	
Breakdown voltage	All the AC inputs ↔ All the DC outputs	2300 V AC, 1 minute (Note)
	All the AC inputs ↔ Protective earth terminals	1500 V AC, 1 minute (Note)
	All the AC inputs ↔ All the alarms	2300 V AC, 1 minute (Note)
Insulation resistance (test voltage: 500V DC)	All the AC inputs ↔ All the DC outputs	100 MΩ or larger
	All the AC inputs ↔ Protective earth terminals	
	All the AC inputs ↔ All the alarms	
Vibration resistance	Based on JIS B 3502 and IEC 61131-2: 5 to 8.4 Hz, half amplitude 3.5 mm 8.4 to 150 Hz, constant acceleration 9.8 m/s ² X, Y and Z axes, 10 sweeps (1 octave/mm)	
Shock resistance	Based on JIS B 3502 and IEC 61131-2 147 m/s ² , X, Y and Z axes, times	
Noise resistance	1500 V[p-p] with pulse widths of 50 ns or 1 μs (based on in-house measurements)	
Environment	Free from corrosive gases and excessive dust.	
EU Directive applicable standard	EMC Directive: EN 61131-2, Low-Voltage Directive: EN 61131-2	
Overvoltage category	Category II or lower	
Pollution degree	Pollution degree 2 or lower	
Weight (main unit)	AFP7PSA1: approx. 240g AFP7PSA2: approx. 290g	

(Note) Cutoff current: 10 mA (Factory default setting)

Specifications

8.2.2 Performance Specifications

Items		Description
Input	Rated input voltage	100 to 240V AC
	Input voltage amplitude range	85 to 264V AC
	Rated frequency	50 / 60 Hz
	Frequency range	47 to 63 Hz
	Phases	Single-phase
	Input current	AFP7PSA1: 0.75A AFP7PSA2: 1.25A
	Inrush current	40 A (0-P) or less; Cold start
	Leakage current	0.75 mA or less between AC input and protective earth terminals
	Momentary power drop time	10 ms or more
Output	Rated output current (Note 1)	AFP7PSA1: 24V DC, 1A AFP7PSA2: 24V DC, 1.8A
	Overcurrent protection (Note 2)	On
Guaranteed lifetime		27,000 hours (+55°C)
Terminal screw		Built-in (Replacement is not available)

(Note 1) Use the unit within the rated output current.

(Note 2) Oscillation is stopped during protected operation.

To recover, turn off the input and then on again. Wait at least 180 seconds before turning the input on again.

8.2.3 Alarm Output Specifications

Items	Description
Contact capacity	1A 30V DC
Alarm contact operations	Contact OFF at CPU alarm occurrence

8.3 Dimensions

8.3.1 Power Supply Unit

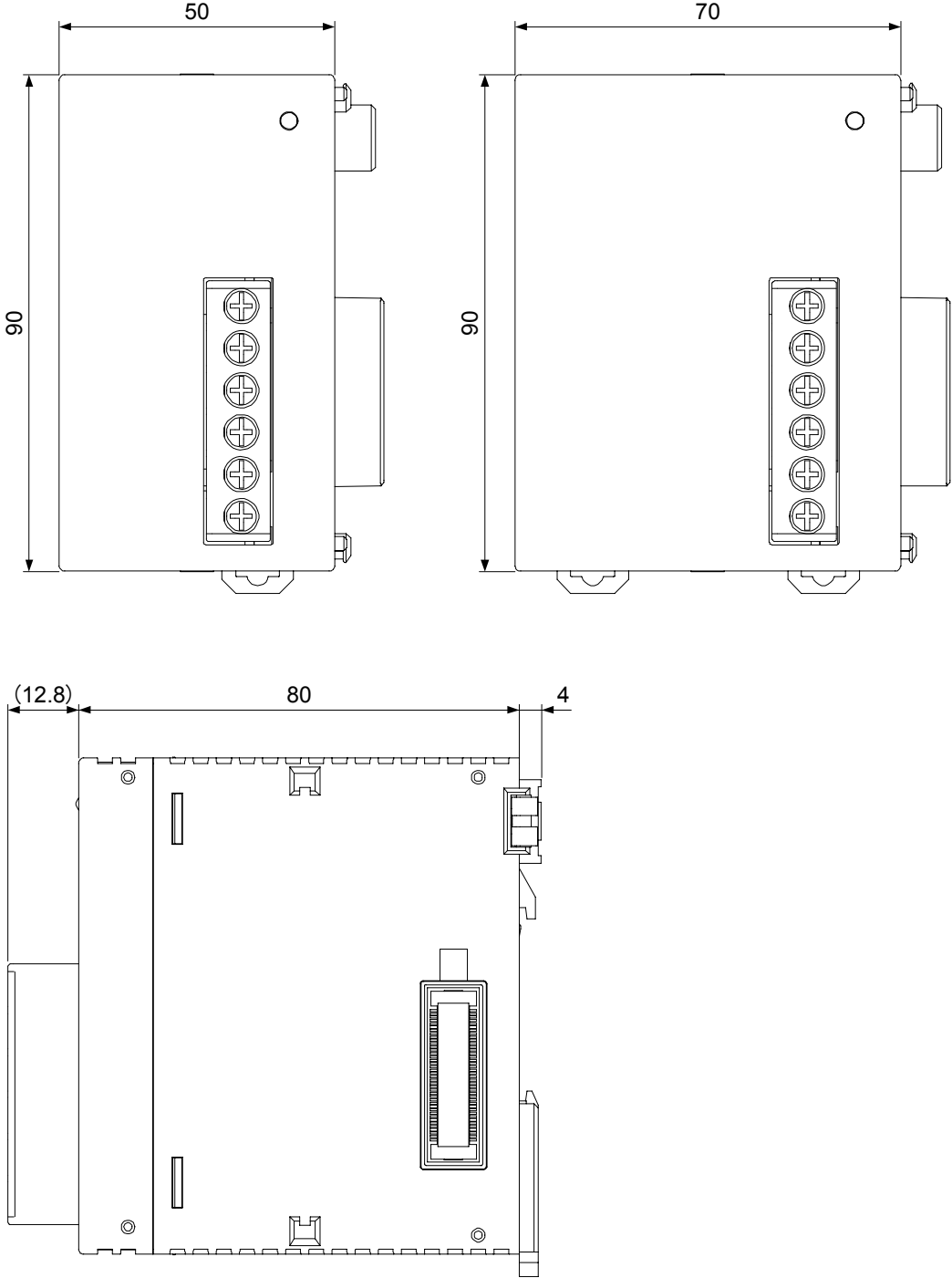

8.3.2 CPU Unit

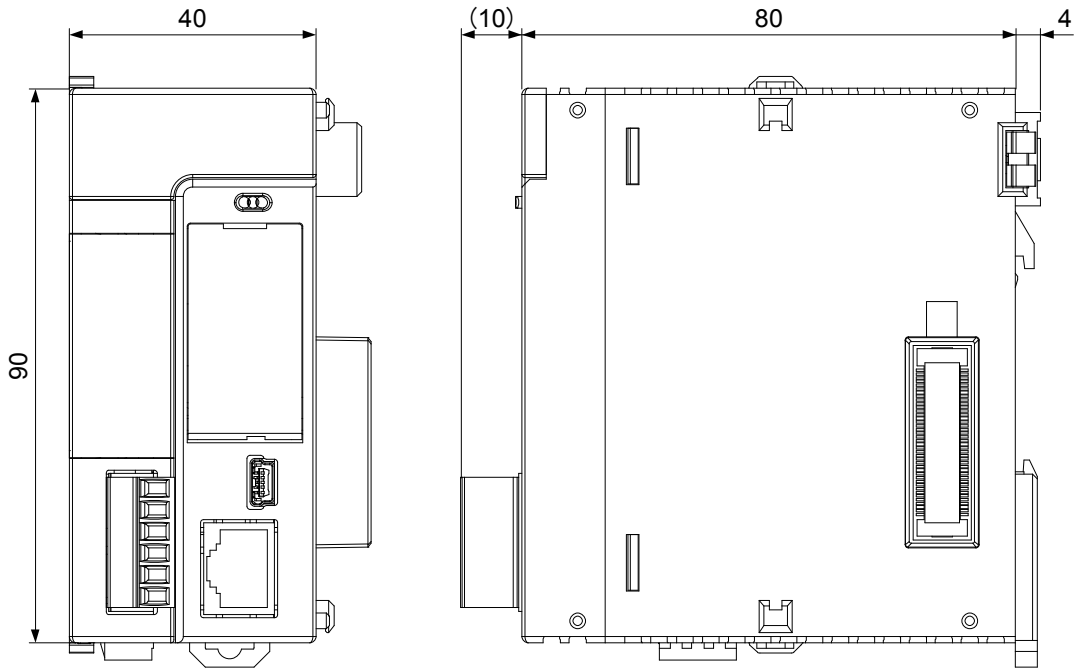

8.3.3 Terminal Block Type Unit (1)

Applicable units: Digital I/O unit (16-point), Analog input unit, Analog output unit

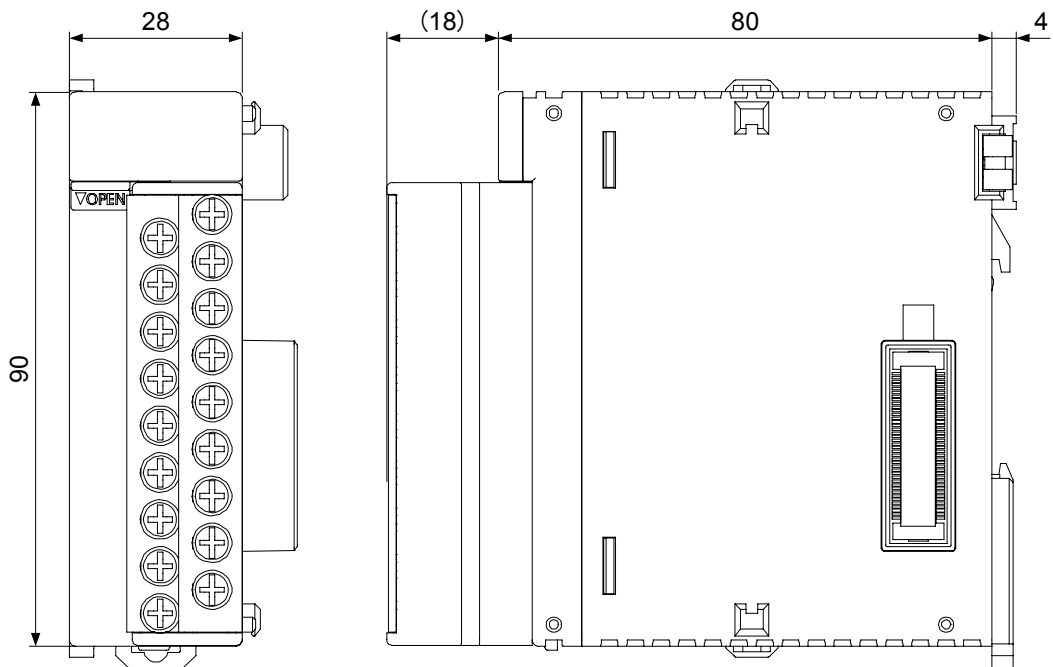

8.3.4 Terminal Block Type Unit (2)

Applicable units: Thermocouple multi-analog input unit, RTD input unit

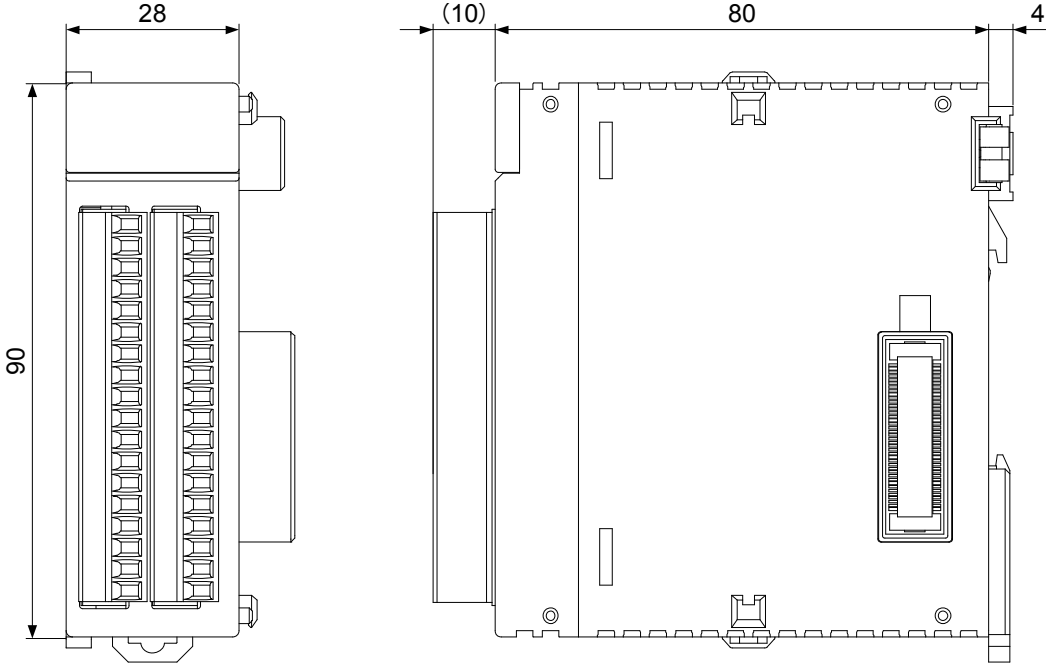

Specifications

8.3.5 Connector Type Unit

(a)	Digital I/O unit (32-point), High-speed counter unit (2-ch), Pulse output unit (2-axis), Positioning unit (2-axis), Expansion master unit
(b)	Digital I/O unit (64-point), High-speed counter unit (4-ch), Pulse output unit (4-axis), Positioning unit (4-axis), Expansion slave unit

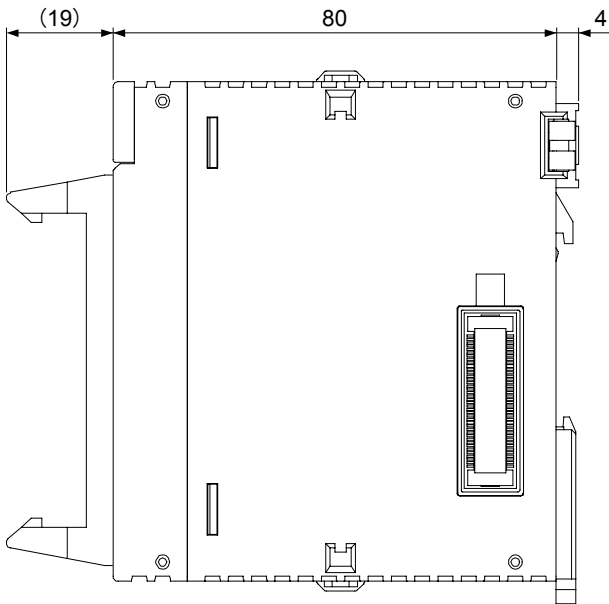
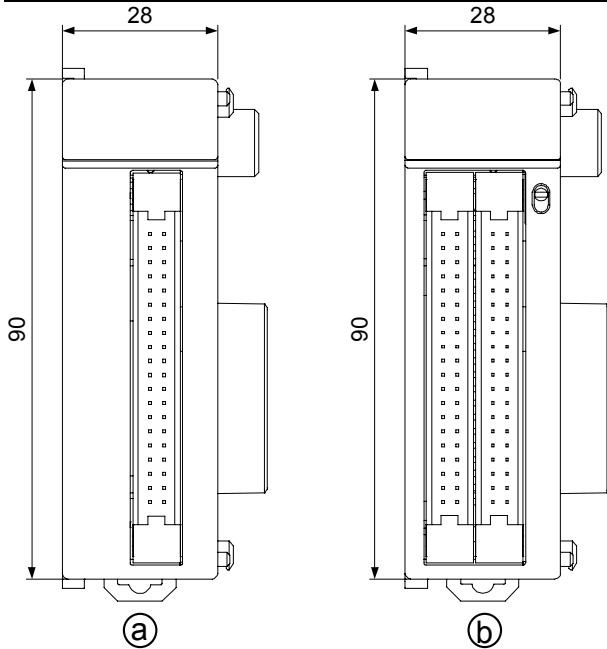

(Note) The expansion slave unit is equipped with a power supply connector.

8.3.6 Serial Communication Unit

The drawing below shows the state that two communication cassettes are attached.

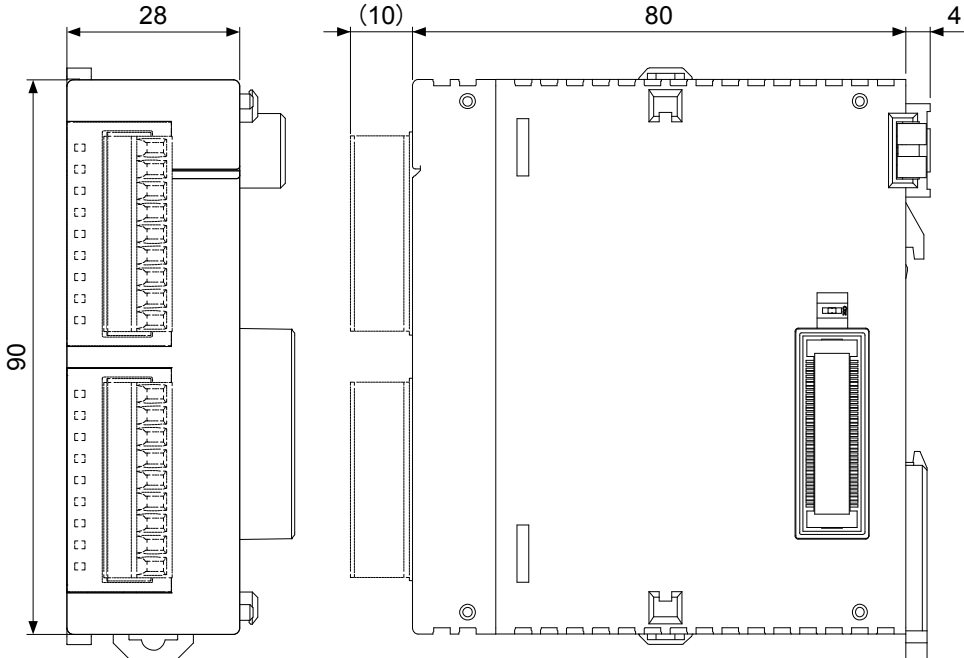

8.3.7 PHLs Master Unit

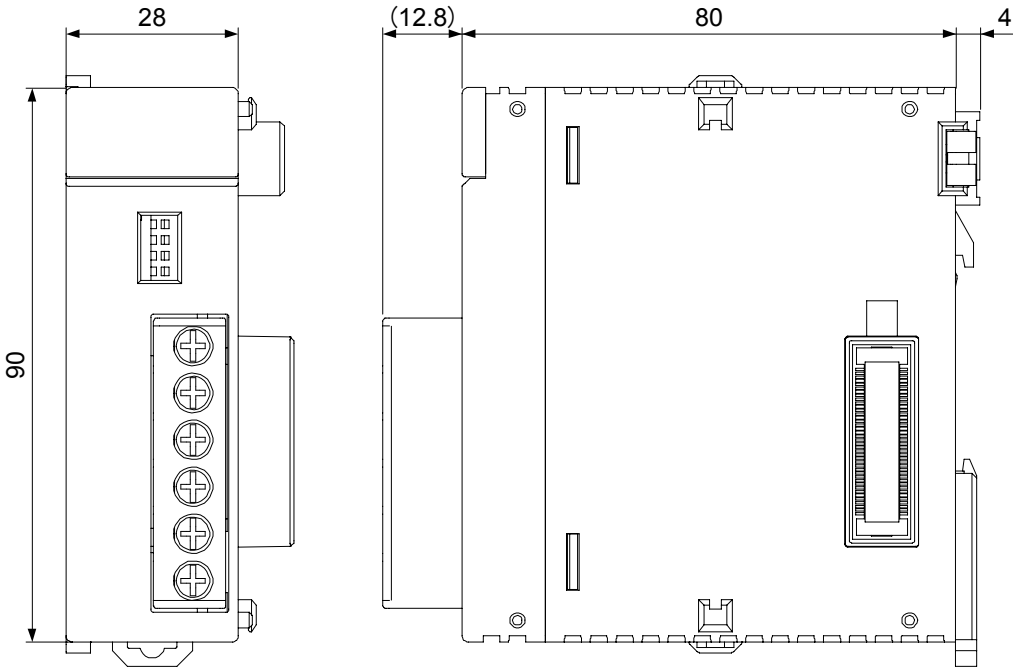

8.3.8 End Unit

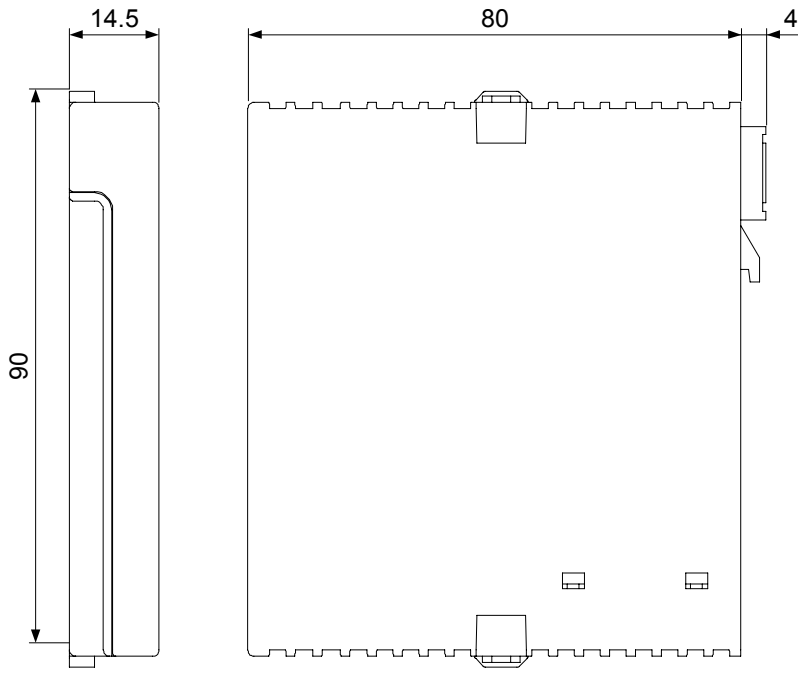

8.3.9 Figures of Unit Combination

■ When the power supply unit AFP7PSA1 is used

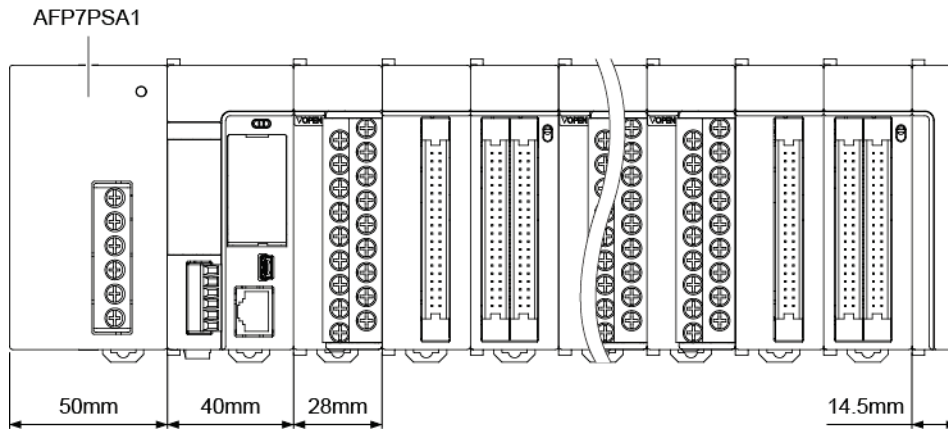

FP7 system full width
 = Power supply unit AFP7PSA1 + CPU unit + n devices (input/output units and intelligent units) + End unit

$$= 50\text{mm} + 40\text{mm} + (n \times 28\text{mm}) + 14.5\text{mm}$$

$$= 104.5\text{mm} + (n \times 28\text{mm})$$

■ When the power supply unit AFP7PSA2 is used

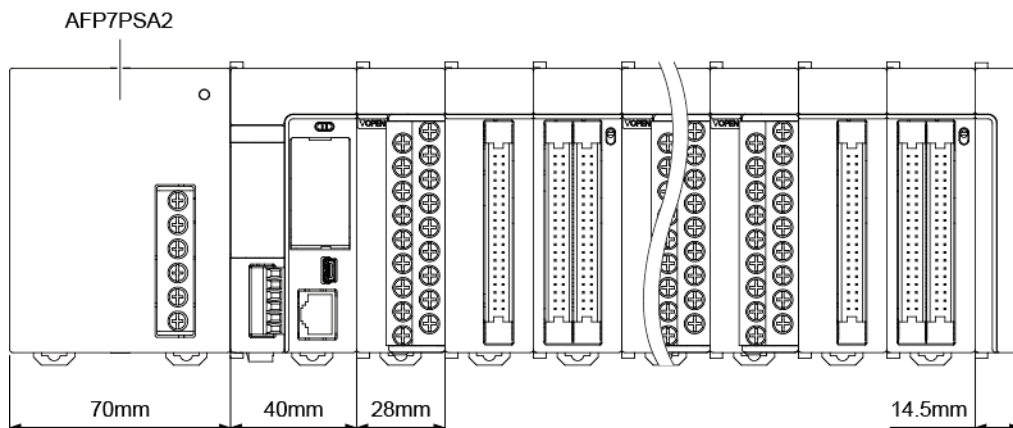

FP7 system full width
 = Power supply unit AFP7PSA2 + CPU unit + n devices (input/output units and intelligent units) + End unit

$$= 70\text{mm} + 40\text{mm} + (n \times 28\text{mm}) + 14.5\text{mm}$$

$$= 124.5\text{mm} + (n \times 28\text{mm})$$

Specifications

■ When no power supply unit is used

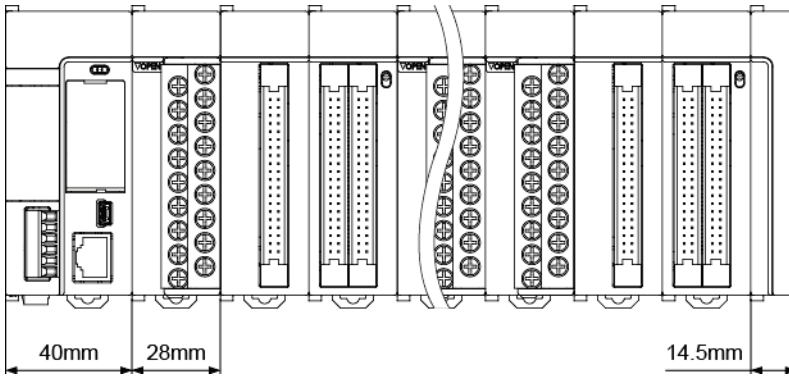

FP7 system full width

= CPU unit + n devices (input/output units and intelligent units) + End unit

= 40mm + (n x 28mm) + 14.5mm

= 54.5mm + (n x 28mm)

Record of changes

Manual No.	Date	Record of Changes
WUME-FP7CPUH-01	Mar.2013	1st Edition
WUME-FP7CPUH-02	Jun.2013	2nd Edition - Added new models CPU units CPS3E and CPS3 I/O units Y32P, Y64P and XY64D2P
WUME-FP7CPUH-03	Oct.2013	3rd Edition - Error correction - Added new models High-speed counter unit
WUME-FP7CPUH-04	Dec.2013	4th Edition - Added new models Serial communication unit AFP7NSC Communication cassette (Ethernet type) AFP7CCET1 CPU unit (Ver.2): AFP7CPS41*, AFP7CPS31* Pulse output unit: AFP7PG02*, AFP7PG04* Analog I/O cassette: AFP7FCA21 Analog input cassette: AFP7FCAD2 Thermocouple input cassette: AFP7FCTC2
WUME-FP7CPUH-05	Aug.2014	5th Edition - Error correction - Added new models Thermocouple Multi-analog input unit AFP7TC8 RTD input unit AFP7RTD8 Analog input unit (8ch) AFP7AD8 Expansion master unit AFP7EXPM Expansion slave unit AFP7EXPS - Added the information of new GUI for FPWINGR7 - Error correction

Please contact

Panasonic Industrial Devices SUNX Co., Ltd.

■ Overseas Sales Division (Head Office): 2431-1 Ushiyama-cho, Kasugai-shi, Aichi, 486-0901, Japan

■ Telephone: +81-568-33-7861 ■ Facsimile: +81-568-33-8591

panasonic.net/id/pidsx/global

About our sale network, please visit our website.